

# **Ex ante evaluation of Grupa LOTOS' Residue Upgrading Project**



**Aalborg University  
Department of Development and Planning  
M. Sc. Environmental Management  
10<sup>th</sup> Semester 2005**

# AALBORG UNIVERSITY

Department of Development and Planning

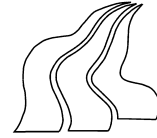

**Title:**

Ex ante evaluation of Grupa LOTOS ' Residue Upgrading Project

**Theme:**

Master's Thesis

**Semester:**

10<sup>th</sup> semester

M. Sc. in Environmental Management

**Supervisor:**

Trine Pipi Kræmer

**Group member:**

Maja Ewa Orlikowska

**Report:** pages 78

**Number of appendix:** pages 13

**Closed:** 15<sup>th</sup> of December 2005

The purpose of this report is to assess the likely success of the Grupa LOTOS' Residue Upgrading Project by looking at its plan via the Five Evaluation Criteria, namely: Relevance, Efficiency, Effectiveness, Impact and Sustainability.

This study evaluates Grupa LOTOS' Residue Upgrading Project design using the approach of the Logical Framework method as its main evaluation tool.

The analysis has been mainly based on forecasts and prospects as the realised worth of the project being evaluated have not had a chance to be realised yet.

The forecasts and prospects indicate that the project is likely to be successful and that stay-in-business environmental projects can also be profitable investments.

# Preface

This report is written as a result of the project for the 10th semester of the M. Sc. in Environmental Management at Aalborg University.

The report consists of 8 chapters and has 3 appendices.

Figures and Tables are referred to with numbers under each chapter. Example: for Figure / Table 1.2, the first digit (1) indicates the chapter while the second digit (2) indicates number (position) on the list of figures or tables within the chapter.

The referencing system is based on the Harvard method, where references are placed in square parenthesis with the last name or organisation and year. If the reference is before a period, it refers to the previous sentence; if it is after a period, it refers to the previous paragraph.

Acronyms are shown on the following page. These will be used through out the project.

15th of December 2005

---

Maja Ewa Orlikowska

## Acronyms

The following table provides the full form of the various acronyms used in this report.

ACEA	Association des Constructeurs Automobiles Européens
API	American Petroleum Institute
AR	Atmospheric residue
ASU	Air separation unit
AusAID	Australian Agency for International Development
BAT	Best Available Technique
bbbl	Barrel
BOC	Base oil complex
BOŚ	Bank Ochrony Środowiska (Environmental Protection Bank)
CO <sub>2</sub>	Carbon dioxide
CDU	Crude Distillation Unit
CIDA	Canadian International Development Agency
DAO	Deasphalted oil
DANIDA	Danish International Development Agency
DFID	Department for International Development
EBI	European Investment Bank
EBRD	European Bank for Reconstruction and Development
EC	European Commission
EU	European Union
GL	Grupa LOTOS
GUS	Główny Urząd Statystyczny (Central Statistical Office)
HCU	Hydrocracking unit
HDS	Hydrodesulphurisation
HDT	Hydrotreater
HFO/HSFO	Heavy fuel oil/ High sulphur fuel oil
HVU	High Vacuum Unit
IGCC	Integrated Gasification Combined Cycle
IPPC	Integrated Pollution Prevention Control
LESA	LOTOS Ekoenergia
LFA	Logical Framework Approach
LPG	Liquefied petroleum gas
LSFO	Low sulphur fuel oil
mb/d	Million barrels per day
MHC	Mild Hydrocracking
MOVs	Means of Verification
Mt	Million tonnes
NORAD	Norwegian Agency for Development
NO <sub>x</sub>	Nitrogen oxides
OECD	Organisation for Economic Co-operation and Development
OPEC	Organisation of Petroleum Exporting Countries
OVI	Objectively Verifiable Indicators

ppm	Parts per million
PROSTA	Petrol Station Network Development Programme
RG	Rafineria Gdańska
RUP	Residue-Upgrading Project
SARU	Soot Ash Removal Unit
SDA	Solvent deasphalting
SIDA	Swedish International Development Agency
SO <sub>2</sub>	Sulphur dioxide
SRU	Sulphur Recovery Unit
STASCO	International Trading and Shipping Company
UK	United Kingdom
UNECE	United Nation Economic Commission for Europe
US	United States
USD	US Dollar
VR	Vacuum residue

# Table of Contents

1. Introduction.....	1
1.1. The oil refining industry .....	2
1.1.1. Petroleum product quality.....	3
1.1.2. Crude oil supply and product demand in the EU.....	6
1.2. Implications and challenges for the EU oil refining industry .....	9
1.3. Research focus .....	12
1.4. Report structure.....	13
2. Background information of Grupa LOTOS.....	14
2.1. Grupa Lotos .....	14
2.1.1. Development history.....	14
2.1.2. Ownership structure.....	14
2.1.3. Organisational structure.....	15
2.2. The core of GL.....	16
2.2.1. Raw material procurement.....	16
2.2.2. The current GL's refinery configuration.....	17
2.2.3. Description of the main products offered by GL.....	19
2.2.4. Sales structure of the main products offered by GL .....	20
2.2.5. Key sales markets of GL.....	21
2.2.6. Other information.....	22
2.3. Development plans of GL.....	22
3. Background information of the RUP.....	25
3.1. The core technologies and their licensors.....	25
3.1.1. The RUP flow description .....	26
3.2. Project financing .....	28
3.3. GL after implementation of the RUP.....	29
3.3.1. GL's refinery configuration and products after 2009 .....	30
3.4. Benefits of the RUP .....	31
3.4.1. Environmental benefits .....	31
3.4.2. Economic benefits.....	32
4. Theories & methods.....	33
4.1. Programme evaluations.....	33
4.2. Logical Framework Approach .....	36
4.2.1. Logical Framework Matrix/ Logframe .....	38
4.2.2. Terminology.....	40
4.2.3. Comparison the LFA with other 'project theories' .....	42
4.2.4. Criticism behind LFA .....	43
4.3. Evaluation approach and LFA .....	45
4.4. Methodology .....	47
4.4.1. Structure of the analysis.....	47
4.4.2. Data collection .....	47
5. Logical Framework Analysis of the RUP.....	49

---

5.1. Problem analysis .....	49
5.2. Objectives analysis.....	50
5.3. Strategy analysis .....	51
5.4. Stakeholder analysis.....	53
5.5. Logical Framework matrix of the RUP .....	54
6. Analysis of the RUP via the Five Evaluation Criteria .....	57
6.1. Relevance.....	57
6.1.1. Needs.....	57
6.1.2. Strategy .....	57
6.2. Efficiency.....	58
6.2.1. Timing of the RUP plan.....	58
6.2.2. Vertical logic from activities to output .....	59
6.2.3. Horizontal logic of the output .....	59
6.3. Effectiveness .....	60
6.3.1. Vertical logic from the output to the project purpose .....	60
6.3.2. Horizontal logic of the project purpose .....	60
6.4. Impact .....	61
6.4.1. Vertical logic from the project purpose to the overall objectives.....	61
6.4.2. Horizontal logic of the overall objective .....	62
6.4.3. What are the other effects beyond the overall objectives? .....	62
6.5. Sustainability.....	62
6.5.1. Environment.....	62
6.5.2. Financial aspects .....	63
6.5.3. Organisational and/or technological aspects.....	63
7. Conclusion .....	65
8. References.....	69
Appendix A: Subsidiaries of Grupa LOTOS .....	1
Appendix B: Brief description of GL's PROSTA.....	5
Appendix C: Logical question list of the RUP – Interview .....	7

# 1. Introduction

Sustainable development is about improving the quality of life while reducing the use of natural resources and pressures on the environment. The quality of life is greatly enhanced by energy, which provides comfort and warmth in homes, mobility for work and recreation, and services that are essential to most industrial and commercial wealth generation. [WCED, 1987; EC, 2005a]

In the European Union (EU), which is the world's second largest energy consumer behind the United States (US), the provision of energy is based predominantly on the use of fossil fuels. The total energy consumption in the 25 Member States has been rising since mid-1990s and this trend is predicted to continue with fossil fuels remaining the largest energy source in the EU for the next 30 years. However, extensive use of fossil fuels, which are the main source of acidifying substances and greenhouse gas emissions, have led to exceedances of tolerable levels of these compounds in the atmosphere contributing to climate change and air pollution. [EC, 2004a; EEA 2004]

The single largest fossil fuel consumed in the EU is oil dominating the whole EU's primary energy mix. Transport is its greatest consumer followed by industry and households. In the future oil will remain the largest source of energy in the EU, although its share will fall marginally due to increasing share of gas and renewables. [IEA, 2004a; EC, 2004a; EC, 2003a]

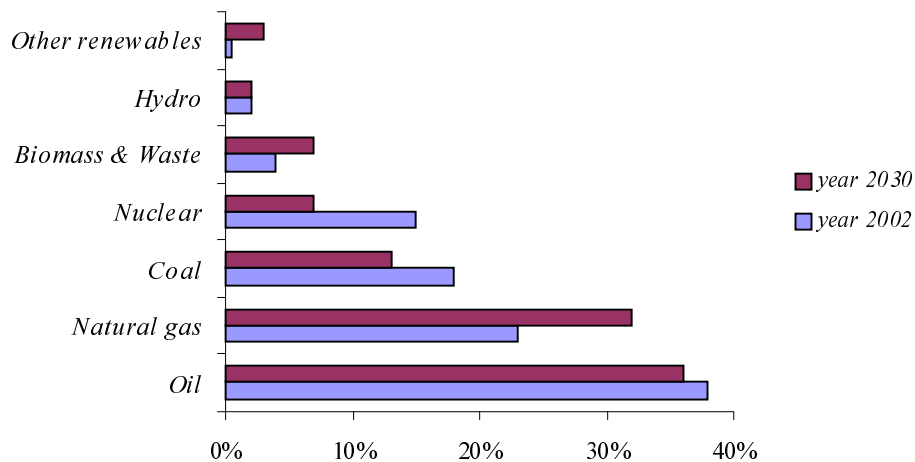

Figure 1.1: EU primary energy mix [IEA, 2004a]

Transport, which is the largest and the fastest growing energy consumer among other sectors, is almost entirely dependent upon oil and renewable energy will contribute very little to its growing consumption [Eurostat, 2005a; EPC, 2003a]. The predominant role of the transport sector in final energy demand is projected to continue and is expected to account for one third of final energy demand in 2030 in the EU [EC, 2003a].



The demand for oil in the remaining oil consuming sectors accounts for less than one quarter and is predicted to have declining tendency due to increasing share of gas and renewables in their final energy consumption (heating and electricity generation). [EC, 2003a]

In order to reduce the level of pollutants and emissions arising from the use of oil and thus lessen its impact on human health and the environment, the European Commission (EC) through a series of directives regulates the sulphur content of certain petroleum products [EPC, 1999; EPC, 2003b]. Improving the product quality has social benefits for society, but at the same time cost and competitiveness implications for the oil refining industry.

## **1.1. The oil refining industry**

The purpose of oil refining is to convert natural raw material such as crude oil into useful saleable products. These products may include [EIPPCB, 2003]:

- Fuels for cars, trucks, aeroplanes, ships and other forms of transport: e.g. gasoline, jet fuel (kerosene), diesel oil, bunker (marine) fuel
- Combustion fuels for the generation of heat and power for industry and households: e.g. heavy fuel oil (HFO), light heating oil/gasoil
- Raw material for petrochemical and chemical industries: e.g. naphtha
- Speciality products: e.g. lubricating oils, paraffin/waxes and bitumen/asphalt.
- Energy as a by-product in the form of heat (steam) and power (electricity)

Crude oil is a mixture of liquid hydrocarbons (chemical compounds containing only hydrogen and carbon 95-99% w/w) plus various impurities among which the most important is sulphur. The liquid ranges from very viscous to easy flowing and has varying molecular weights differing from one another in structure and properties. The composition of crude oil is the most important parameter in establishing the range and quality of products that may be produced from a refinery. The impurities of crude are also very important in establishing the value of the crude and the difficulties in converting it into marketable products. [EIPPCB, 2003]

Statistical analysis of price differentials has focused on two main properties: the specific gravity (lightness) measured in degrees API (a scale devised by the American Petroleum Institute) and the percentage of sulphur content by weight. The total sulphur content may be as low as 0.04% w/w or as high as 5% w/w. Crude oil containing more than 0.5% w/w S are commonly referred to as “sour” and the others as being “sweet”. [World Bank, 2004; EIPPCB, 2003]

Heavy crude oils (API gravity less than about 28-32 degrees) have higher percentages of heavy, high boiling range materials that require additional investments in refinery equipment in order to convert those heavy volumes into gasoline and middle distillates

(diesel oil/gas oil, kerosene). The sour crude oil also requires extra investments to remove the sulphur. In addition, in many countries (EU, US, Canada, Japan and Asia Pacific region) legislation mandates lower sulphur content for gasoline and diesel. Thus, heavy, sour crude oils are sold for a lower price than higher quality light, sweet crude oils. [World Bank, 2004; FWC, 2004; ICF, 2005; EIPPCB, 2003]

Global crude oil slate is becoming heavier and sourer with sweet crude oil accounting for just 19% of total oil reserves. An increase in the share of high-sulphur crude in the world market together with a relative increase in the demand for low-sulphur products, result in even larger discounts for sour crudes. [BCG, 2005; World Bank, 2004]

The main regions where light sweet oils are produced are Africa (mainly Algeria, Libya and Nigeria) and Europe (North Sea crude oil producing regions). North Sea crude called Brent Blend is a combination of crude oil from 15 different oil fields located in the North Sea. Its API gravity is 38.3 degrees and contains about 0.37 percent of sulphur (making it a light sweet crude oil). Brent crude forms a benchmark for pricing the oil production from Europe, Africa and the Middle East flowing West meaning that price for other crude oils is often priced as a differential to Brent. [EC, 2003b; EIA, 2004a; Wikipedia, 2005]

### **1.1.1. Petroleum product quality**

Product quality is subject to European Directives, which have set a timetable for enhancing characteristics of petroleum products to meet air quality improvement targets. Specifically, the limits on the sulphur content of HFO and bunker fuel are becoming increasingly stringent while for petrol and diesel fuels, the stated objective is 'sulphur free'. The target is supported by automakers, who are adapting their vehicles to cut pollutant emissions as well as fuel consumption.

#### **Rationale for reducing sulphur content in HFO and bunker fuel**

HFO and bunker fuel consist largely of the residue remaining from the distillation of crudes. This residue generally has high sulphur content thus combustion of residual fuels results in offgases containing sulphur dioxide (SO<sub>2</sub>). The higher the sulphur content in residual fuels the larger emissions of SO<sub>2</sub>, which contribute to the problem of acidification and formation of particulate matter in the atmosphere. [EIPPCB, 2003; EPC, 1999]

The acidification damages soil and water quality, crops and other vegetation as well as terrestrial and aquatic ecosystems. Acid falling in cities damages buildings and is linked to adverse health effects, both directly and through particulate formation, particularly among those sectors of the population suffering from respiratory diseases. [EPC, 1999]

The first sign of the effects of acid deposition in Europe was the loss of fish populations in Scandinavian lakes in the early 1960s. It was found that the water in the lakes was acidified to a point at which fish eggs no longer produced young specimens. A few years later, reports from Germany indicated unusual damage in forests. Trees showed decreased

foliage or needles, and this damage even progressed to the point that trees would die, a phenomenon that happened in the border area of former East Germany, Poland, and former Czechoslovakia. [Erisman, 2004]

Between 1972 and 1977 several studies confirmed the hypothesis that air pollutants could travel several thousands of kilometres before deposition and damage occurred. This implied that co-operation at the international level was necessary since air pollution was recognised as a transboundary problem requiring agreement by governments world-wide or regionally on measures to deal with it. [UNECE, 2005]

The first international treaty with strategies for reducing transboundary air pollution was the United Nation Economic Commission for Europe (UNECE) Convention on Long Range Transboundary Air Pollution which entered into force in 1983. The Second Sulphur Protocol (UNECE, 1994) used the approach of setting emission targets to reduce the exceedance of critical deposition levels for ecosystems. [EEA, 2002]

Actions to reduce SO<sub>2</sub> emissions have been taken at the EU level through measures that include targets for reducing total SO<sub>2</sub> emissions for the EU and each Member State set in the national ceiling directive. To help reach these targets, European Community legislation aimed at reducing acidifying pollutants includes a Directive on the reduction of emissions from large combustion plants. Large Combustion Plant Directive, provides for emission limits values of 1700 mg/Nm<sup>3</sup>. Also the control of emissions of SO<sub>2</sub> originating from combustion of certain liquid fuels has been identified as integral component of the strategy to combat acidification in the EU. [EEA, 2002; EIPPCB, 2003; EPC, 2001]

The sulphur specification for fuel oil used inland for power generation and by industry has been reduced from 3.5%wt to 1%wt, which equates 1700 mg/Nm<sup>3</sup> of SO<sub>2</sub> emissions, and has already been applying in the EU from 2003. Since ships are one of the leading sources of SO<sub>2</sub> emissions in the Union, Members of the European Parliament ratified stricter limits for sulphur content in marine fuels to come into effect starting May 2006. This implies sulphur content in bunker fuel oils sold within its boundaries to between 1 and 1.5 %wt. [EPC, 1999; EC 2003c; BW, 2005]

### **Rationale for reducing sulphur content in petrol and diesel fuels**

Climate change is potentially the most serious environmental problem with far-reaching ecological, health and economic consequences. The principal greenhouse gas, responsible for global warming is carbon dioxide (CO<sub>2</sub>) – the major anthropogenic source of which is burning of fossil fuels. When hydrocarbons are burned - CO<sub>2</sub> comes from the chemical recombination of carbon with the ambient oxygen. As a result of human actions, greenhouse gas concentrations in the atmosphere are now higher than at anytime in the past 450 thousands years. Since the industrial revolution, the concentrations of CO<sub>2</sub> have risen from 280 parts per million (ppm) to around 380 ppm. The burning of oil is believed to account for 42% of world CO<sub>2</sub> emissions. [EC, 2005b; IFP, 2002a; IEA 2004b]

Release of increased amounts of CO<sub>2</sub> affect the level of absorption and emission of the sun's radiation through the earth atmosphere resulting in global warming. Over the past century, global average temperature has risen by about 0.6°C, and mean temperature in Europe has increased by more than 0.9°C. Globally, the 10 warmest years on record all occurred after 1991. Current greenhouse gas emissions will lead to further temperature increases during the 21st century. [EC, 2005b; EEA, 2004]

The heat wave that occurred in Europe during the summer of 2003 is considered by experts to be the likely effect of climate change. During that summer, more than 20 thousands people in the EU died from a combination of heat stress and increased air pollution from ozone and particulates. Southern Europe suffered large-scale forest fires. European farmers lost over € 10 billion in income. There has also been an increase in weather-related natural catastrophes, such as floods and windstorms. A survey of the years 1950 to 2003 conducted by the world's largest re-insurer Munich Re shows that between 1994 and 2003 there were almost three times as many weather-related natural catastrophes as in the 1960s. Sea levels have risen by 10-20 cm over the last 100 years. Over the last 30 years, the extent of Arctic sea ice has decreased by circa 7% and the ice has thinned by about 40%. [EC, 2005b]

It is projected that ecosystems will suffer from climate change, with some species and habitats disappearing. Global food production is likely to decline; infectious diseases may spread, and water scarcity and quality is likely to be an issue in many regions. If global greenhouse gas emissions are not reduced, sea levels are expected to rise by 9-88 cm by 2100. This would drown some low-lying islands (e.g. the Maldives) and many coastal regions (e.g. the Bangladesh delta), and cause widespread salt-water intrusion. Weather impacts are likely to include higher maximum temperatures, more heat waves, increased summer drying with the risk of drought and fires, or, in other regions, increases in precipitation, storms and floods. Such impacts might have secondary effects, such as regional conflicts, poverty, famine and migration. [EC, 2005b]

An international efforts to curb climate change under the 1992 United Nations Framework Convention on Climate Change is the Kyoto Protocol, which entered into force on 16 February 2005. It legally obliges industrialised countries to meet targets with regard to their emissions of greenhouse gases during a first commitment period from 2008 to 2012. The Kyoto Protocol commits the EU to decrease its greenhouse gas emissions by 8 % between 1990 and 2008/2012. [EC, 2003d; UNFCCC, 2005]

The major concern in meeting this objective in the EU has been the transport sector. CO<sub>2</sub> emissions from transport have increased constantly since the 1970s, in parallel with economic development and alongside the rise in fuel consumption. Transport was already responsible for 28% greenhouse gas emissions in 1998 and this share is likely to rise of 50% between 1990 and 2010. Road traffic seems to be prominent in this pollution, it generates 84% of CO<sub>2</sub> emissions attributable to transport. [IFP, 2002a; EC, 2004a]

The main automaker associations, including Association of European Motor Manufacturers (Association des Constructeurs Automobiles Européens - ACEA), have undertaken to limit average CO<sub>2</sub> emissions from new vehicles sold in Europe to 140 g/km in 2008 (compared with 164 g/km in 2002). [IPF, 2002a]

ACEA's commitment to the EC on reducing the CO<sub>2</sub> emissions of passenger cars is subject to appropriate fuels ('sulphur free' - containing max. S content of 10 ppm) being widely available. ACEA members plan to commercialise lean burn direct injection petrol engines with a fuel efficiency performance similar to the best diesel engines as part of their strategy to reduce CO<sub>2</sub> emissions. The exhaust from this kind of engine is different from conventional exhaust. Oxygen levels are much higher and this prevents standard three way catalytic converters from controlling nitrogen oxides (NO<sub>x</sub>) emissions. Advanced NO<sub>x</sub> exhaust catalysers have to be used and these are highly sensitive to the presence of sulphur. [ECMT, 2000]

Since 'sulphur free' fuel is a pre-requisite for the development of a new engine technology the aim of which is reduction of CO<sub>2</sub> emissions from passenger cars, the European Commission prescribes the sulphur specification for gasoline and diesel to an eventual standard limit of 10 ppm S applying in the EU from 2009. [EPC, 2003b]

Producing sulphur free fuels will result in additional CO<sub>2</sub> emissions from refineries, potentially undermining the CO<sub>2</sub> emissions reductions targeted by ACEA. However, matching the supply of sulphur free petrol reasonably closely to the demand for its use in lean-burn engines would limit the impact on the overall CO<sub>2</sub> emissions balance. The EC consultation concluded that once new fuel-efficient engines equip around 50% of vehicle sales a net reduction in CO<sub>2</sub> emissions is likely. [ECMT, 2000]

### **1.1.2. Crude oil supply and product demand in the EU**

Global oil demand has been growing (the main reason for the growth in demand in recent years is a higher consumption in Asia, particularly in China). It is expected to average 83.5 million barrels per day (mb/d) in 2005 (this level is 1.4 mb/d higher than that noted in 2004) and 85.3 mb/d in 2006. [IEA, 2005a]

The world's largest producer of oil is Saudi Arabia a member of Organisation of Petroleum Exporting Countries (OPEC), producing approximately 10 mb/d. The total production of all OPEC (Algeria, Indonesia, Iran, Iraq, Kuwait, Libya, Nigeria, Qatar, Saudi Arabia, the United Arab Emirates, and Venezuela) accounts for about 40% of global oil production. Apart from OPEC, Russia, the United States, Mexico, China, Norway and Canada are also major oil producers. With the exception of Russia and Norway, the oil produced by these countries is mainly used for their own needs. [EIA, 2005a; EIA, 2004b]

It is expected that global oil demand will rise by 28 mb/d to 111 mb/d by 2025 — an annual average growth rate of 1.5 %. However, more than three-quarters of the increase in

demand over the next 20 years will come from developing countries, whose consumption will almost double. Asian countries will remain the key source of oil demand increase in the developing world, with China and India central to this growth. In 2005 European oil demand accounted for 16.31 mb/d and is expected to grow until 2030 at annual growth rate of 0.3%. The transportation sector will account for almost 60 % of the rise in global demand over the next two decades. [OPEC, 2005; EC, 2003a; IEA, 2005a]

OPEC, and the Middle East in particular, will remain the largest supplier of world oil markets, however, the significance of other oil producers than OPEC is expected to grow in the longer term. Production from Russia and the Caspian region is expected to grow at a larger rate than any other non-OPEC region. By 2020, production could almost double to more than 14 mb/d, with the significant share of the growth coming from Russia. [EMC, 2002]

Russia's large undeveloped oil reserves are primarily located in remote areas - far from markets and infrastructure and many in difficult Arctic onshore and offshore environments. In addition, the complex geology often requires unique technical solutions to maximise the recovered barrels per dollar or ruble invested. Delivering these resources at a cost that is competitive with alternative supplies is critical to increasing Russian production. As the oil sector is strategic for this country, not only in terms of energy security but also budget income, a State intervention in this area cannot be ruled out. [EMC, 2002; EIA, 2005b]

### **The EU crude oil supply**

Oil reserves are unevenly distributed across the world, and the EU in particular has very few accounting for 0.6% of the world's proven oil reserves [EIA, 2005c]. Denmark and the United Kingdom (UK) are the only EU-25 oil exporting countries, while 20 of the Member States are over 90% dependent on imported oil [Eurostat, 2005b]. The EU member countries import oil predominately from the Former Soviet Union, the Middle East (Saudi Arabia, Iran, Iraq, Kuwait) Africa (Nigeria, Libya, Algeria, Egypt), and Norway [Eurostat, 2003].

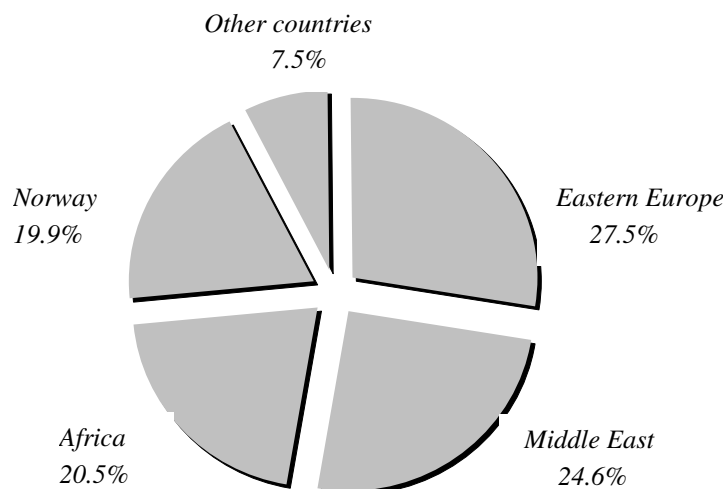

Figure 1.2: Share of oil imports in the EU in 2002 [Eurostat, 2003]

The availability of the type of crude oil to EU's refineries is not the same. The crude slate processed in north-western Europe contains a higher proportion of better quality crude than other regions due to close location to oil fields where this kind of crude is produced. EU oil imports from Libya, Algeria and Nigeria goes mainly to Italy, Germany and France while the largest recipients of Brent Crude in Europe, apart from producing countries (Norway, UK, Denmark) are Germany, Netherlands and France. [EIPPCB, 2003; EIA, 2005d; EIA, 2005e; 2005f; EIA, 2005g].

There has been declining production from the North Sea since its output peaked in 1999. In order to compensate for North Sea decline and ensure security of supply the EU has been developing projects to upgrade the existing and build new oil import transportation pipelines from the existing and potential suppliers. One of these projects includes the Odessa-Brody-Płock-Gdańsk oil transportation project. The Odessa-Brody (Ukraine) to Płock-Gdańsk (Poland) pipeline will constitute the first EU oil transportation corridor from the Caspian Sea region. The Odessa-Brody pipeline allows Caspian light sweet oil that is piped to Black Sea ports to be shipped across the Black Sea to a terminal near Odessa and then transported to Brody. Connecting the Odessa-Brody oil pipeline to the system of Polish transportation networks would open a way for oil from the Caspian Sea region to reach Central and Eastern European countries, while extending the pipeline to Gdańsk will allow Caspian crude oil to reach to Scandinavia and Western Europe through the Baltic Sea ports. EU also envisages extending and upgrading oil pipelines from North Africa as imports from these countries are projected to increase. [IAGS, 2004; EC, 2003e; EC, 2004b; EIA, 2004c; EIA 2005f; EIA, 2005g]

### **The EU petroleum product demand**

In 1985, Western Europe consumed 180 million tonnes (Mt) of road transport fuel, with gasoline representing 60% and diesel fuel 40%. In 2004, total consumption exceeded 270 Mt, an increase of nearly 50% in twenty years, and the breakdown was reversed: diesel accounted for 60% and gasoline 40%. While gasoline demand rose by 7%, the consumption of diesel fuel for road transport more than doubled during the period 1985-2003. By 2010 the market is expected to have grown to 295Mt, but with a 68% diesel/ 32% gasoline split. The drivers for diesel growth are lower taxes on diesel in all European countries, apart from the UK, its lower carbon dioxide emissions/km and its higher fuel efficiency. However, with the pressure for a 140 grams CO<sub>2</sub>/km standard in 2008, diesels are favoured as the only engine type that can currently meet the standard. Technological developments are also favouring diesel, with further developments underway, notably very high pressure injection systems. This is expected to lead to diesel dominating the motor fuel market by 2010. Average annual growth rate between 1995-2010 is to be equal to 0.7 and 2.3% for gasoline and diesel respectively. [IFP, 2005; EI, 2005 EIPPCB, 2003]

Demand for jet fuel has grown at a rapid rate over the last two decades. Consumption of jet fuel increased by 52% between 1980 and 1990 and by a further 61% between 1990 and 2000. Over the last four years jet fuel demand has declined with cutbacks caused by

terrorist attacks of September 11th, SARS and the Iraq war. However, the growth trend now seems to have been re-established and is expected to continue. Average annual growth rate between 1995-2010 is to be equal to 2.7%. [EI, 2005; EIPPCB, 2003]

Inland HFO demand is expected to decline with an average annual rate of 2.6% while bunker fuel demand is expected to grow slowly (0.7%), with a move from high sulphur to low sulphur grades now starting. The annual growth rate is to be true for the years 1995-2010. [EI, 2005; EIPPCB, 2003]

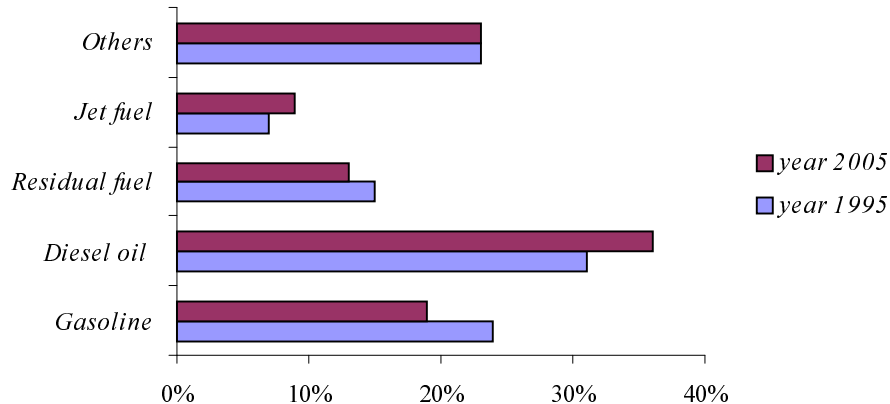

Figure 1.3: Petroleum product demand breakdown in Europe (years 1995 & 2005) [IEA, 2005b]

## 1.2. Implications and challenges for the EU oil refining industry

The oil refining industry which transform crude oil to finished products directly usable by the end-users must constantly adapt to the changing quantitative demands of the market place. In the EU refinery production quantities are currently affected by two trends:

- growing demand for transport fuels
- potential reduction in markets for HFO (industrial consumers are gradually replacing HFO with natural gas)

The second major issue facing European refiners is the need to comply with increasingly stringent environmental legislation, both in terms of product quality specifications regarding the sulphur content in both transport fuels as well as HFO and restrictions of SO<sub>2</sub> emissions from the refinery site (Large Combustion Plant Directive).

The market demand for the type of products, the available crude quality and certain requirements regarding product quality set by authorities influence the size, configuration and complexity of a refinery. [EIPPCB, 2003]

Demand for heavy sour crudes is growing significantly more slowly than for light sweet categories of oil. Crude oils that are heavier and those that have higher concentrations of



impurities, especially sulphur, require more elaborate and expensive installations to produce a given proportion of the lighter products such as gasoline, diesel and kerosene as compared to light sweet crudes. In addition, reducing the sulphur content of refinery products results in larger amounts of heavy petroleum processing residuals (the left-over after the higher valued products are removed from crude oil) with higher sulphur content. Traditionally heavy refinery residues have been sold as a marine bunker fuel or used as a furnace fuel on refinery site or in power stations. However, following the requirements regarding sulphur content refiners have had to add increasing quantities of good quality cutter stock (e.g. gasoil) to sell it as commercial fuel for ships and utilities or use in the refinery as a furnace fuel. Unlike light products, such as gasoline and middle distillates, HFO commands the price below the cost of crude thus depressing refinery margins (difference between cash income from product sales and the cost of crude oil plus utilities). In order to dispose of the residual oil, refiners processing lower-quality crudes would have to invest in major clean-up investment (e.g. sulphur removal plant). However, due the shrinking market for residual fuel and its low value refineries are not eager to pay for major clean-up investment. Those units have usually high capital and operating cost and thus are primary used as a feed treatment for conversion units and not for production of low sulphur fuel oil (LSFO). The most cost-effective way to produce LSFO would be processing of sweet crude oil. [JC, 2003; ILO, 1999; EC, 2003b; EIPPCB, 2003]

Decline in demand of HFO, together with an increase in the need for transportation fuels, is motivating refiners processing lower quality crudes to look for new residual oil outlets and flexible refinery schemes that can improve production of lighter fuels. There are a number of different residue-upgrading technologies available to meet the refiners differing needs, which offers the opportunity to produce the required, low-sulphur transportation fuels by residue upgrading rather than additional crude processing. [FWC, 1999]

The ability to make light products is measured by "conversion capacity", i.e. the percentage share of the output of distillation (first-stage of refining) able to be converted in further stages to lighter products. Conversion capacity is a rough measure of how highly developed refinery installations are. [ILO, 1999]

Processing heavy sour crudes is more costly than processing light sweet crudes. However, the widening price differentials between light and heavy and sweet and sour crude with the same prices of final products, increases the competitive position of refineries that have capacity for upgrading to handle a greater quantity of heavy and sour crudes. [BCG, 2005]

Sweet/sour crude price differential in Europe is presented as a discount in the price of Ural to Brent. Ural crude oil originates from deposits in Russia and due to its chemical and physical characteristics is classified as (1.17% w/w S, API gravity -32.2 degrees) medium and sour. [Hydro, 2005; BCG, 2005]

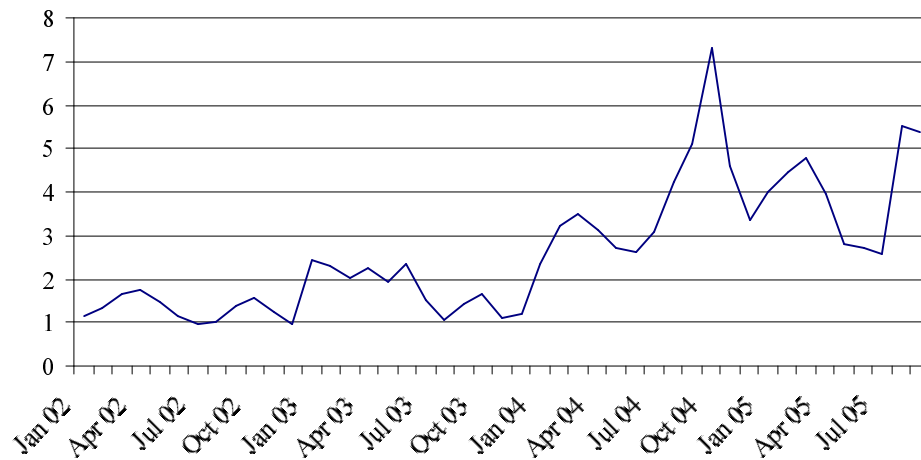

Figure 1.4: North Sea Brent premium to Russian Urals in USD for the years 2002- 2005 [IEA, 2005c]

The wide price gap between low- and high-sulphur crude oils is the result of an underinvestment in conversion capacity in refineries at a time when tighter environmental standards put sour crudes at a disadvantage to sweet crudes. The divergence of the sweet and sour markets therefore is unlikely to be quickly resolved and the spread between the two is expected to remain volatile. [MEES, 2005]

On the other hand, the possible supply of the Caspian oil and planned increased supply from Libya can stabilise the prices of light sweet crude oil. [Kublik & Malinowski, 2005]

In the EU countries, including new EU members, refineries either process light, low-sulphur crude or are processing heavy sour crude, and have already invested (or planning to invest) in residue conversion units. [Kublik & Malinowski, 2005]

Refinery operators whose expectations about the crude slate and the changing proportions of refinery products are justified have a better chance than those who get it wrong of adding heavy investments which is well suited to market conditions and, therefore, being profitable. The heavy investments involved in such installations will be justified if the price differential between low-quality crudes and high-quality crudes is sufficiently great. Similarly, the amount and type of investment will be influenced by the refiner's expectations about product demand (proportions there will be a market demand for the various products). Where demand is sufficiently strong for the lighter products, so that they command a sufficient price premium, the investments in capital intensive technologies needed to increase the proportion of such products will be justified or alternatively the refiner will pay the premium to use a lighter, higher-quality feedstock. [ILO, 1999]

In order to meet tightening environmental legislation and increased demand for high quality transportation fuels, refiners are faced with the choice of purchasing light sweet crudes at a premium price, or increase conversion capacity, through installing upgrading equipment that converts residual material to higher valued products.

### 1.3. Research focus

The research focus of this report is Grupa LOTOS (GL), the second largest producer of liquid fuels and oil derivatives in Poland.

Poland can hardly be called an oil producing country where annual production of almost 0.9 Mt meets only 4.8% of domestic consumption. Available deposits in Poland are estimated at 12.6 Mt, and therefore accounting for less than annual consumption (20Mt). Following Poland's entry into the EU in 2004, long-term forecasts estimate further growth in Polish oil consumption up to 25 Mt in 2015. [BRE Bank, 2005]

The logistics infrastructure of Poland allows for alternative supplies of crude oil from two directions: by 'Przyjaźń' ('Friendship') Pipeline from Russia through Belarus, and by sea with unloading at the North Port in Gdańsk. In the geographical structure of crude oil imports to Poland, Russia holds the dominant position (about 94.5% of supplies), the North Sea region countries and the Arab countries have much lower shares. Since Poland participate in Odessa-Brody-Płock and Odessa-Gdańsk Oil Transportation Project the possible other directions of oil supplies may include the Caspian Sea region. [MGIP, 2005]

The case has been chosen because the company primarily process Ural crude and plans to implement its Residue Upgrading Project (RUP) based on installation fully adjusted to the processing of heavy crudes. The key strategic drivers for the GL's Residue Upgrading Project are reducing refinery emissions as well as production of HFO, and producing more higher value products – all in line with EU standards. The intention behind this investment is to achieve the largest possible output in processing oil from Russia since currently, processing Urals proves to be the most profitable due to the logistics and lower purchasing cost compared to oil from other sources. [Zgoda et al., 2005]

The purpose of this report is to assess the likely success of the GL's Residue Upgrading Project and check its potentials to meet challenges GL faces in meeting quantitative market's demand and EU legislation regarding tightening fuel specifications and facility emission controls. It does this through making the following study:

*“Ex ante evaluation of Grupa LOTOS Residue Upgrading Project”*

In this report “ex ante evaluation” is an appraisal of GL's Residue Upgrading Project design using a Logical Framework Approach (LFA) as its main evaluation tool. LFA presents information about the key components of a project in a clear, concise, logical and systematic way, which will facilitate the evaluation of the project's relevance, effectiveness, efficiency, impact and sustainability.

Feedback of the results of the evaluation can be utilised to improve the project design when taking into account external factors (which could affect the progress or success of the

project) and/or indicate whether environmental concern can be turned into profitable advantage.

## 1.4. Report structure

The structure of the report can be divided into the five sections as illustrated in the figure below.

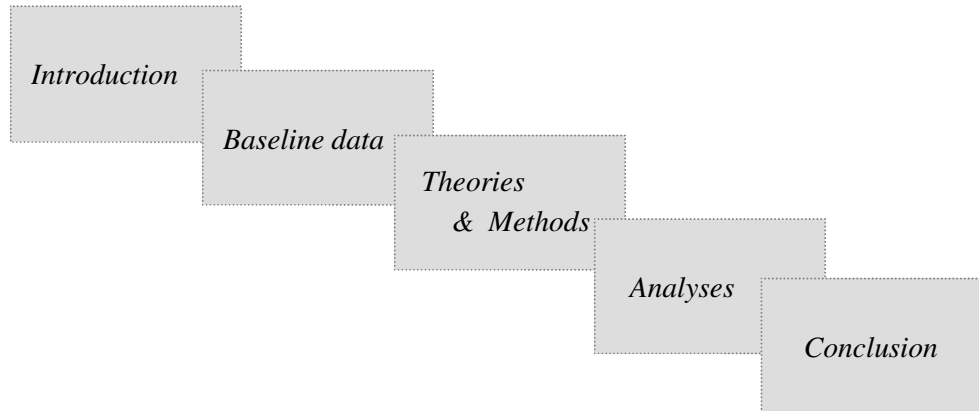

*Figure 1.5: Report structure*

Following the Introduction the paper provides background information about GL and gives an overview of its Residue Upgrading Project. The information presented in these chapters serve as a baseline data for the analyses. Then theories and methods to be applied in the analyses are discussed together with their impact on the final results. Analyses section starts with presenting the logical structure of the GL's Residue Upgrading Project. The end product of the LFA will be used for the examination of the proposed project via the Five Evaluation Criteria. The report concludes with general assessment of GL's Residue Upgrading Project.

## **2. Background information of Grupa LOTOS**

This chapter provides background information about GL including its development history, the current ownership and organisational structure and the description of the company's business as well as the information related to its main products. What follows is a brief presentation of the company development plans, which serves as the introduction to the following chapter.

### **2.1. Grupa LOTOS**

GL is Poland's second leading producer and distributor of oil and petroleum products (21% of the domestic total engine oil sales), following PKN Orlen Group (60% of the domestic total engine oil sales). The company also operates on the wholesale and retail markets. Sales on the wholesale level are conducted throughout the country by the members of the group. Retail sales occur mainly through the mediation of the network of petrol stations: company-owned, patron, and partner stations. GL owns the numerically second largest petrol station network in Poland. [BRE Bank, 2005]

#### **2.1.1. Development history**

The history of GL dates back to 1972, when construction of the refinery in Gdańsk began. Production was launched three years later. The company operated under the name Rafineria Gdańska (RG) until June 2003. The adoption of the new name occurred during organisational changes in RG and the company name was changed to Grupa LOTOS - inspired by the considerable market success that the motor oils sold under the LOTOS brand have enjoyed for some time. [Gacek, 2003]

Until 2002 the business and organisational structure at RG was mainly concentrated on production with little experience in competing for market share (13% in 2001), and despite a deficit of fuel in Poland, RG exported a major portion of its products. The change in the management board in 2002 brought changes in the way the company operates. The main emphasis was placed on the development of distribution channels and obtaining a position on the domestic market. This implied corporate and organisational restructuring resulting in that the areas of business that did not belong to RG basic activities - refining crude oil and processing it into finished products have been separated off from the existing organisational structure to operate in strictly defined market sectors. The separated entities have been integrated by a computerized information system and taken the word "LOTOS" in their name thus indicating that they belong to GL. [Gacek, 2003]

#### **2.1.2. Ownership structure**

Initially, the company was wholly owned by the Polish State Treasury. Efforts aimed at privatising GL began in the second half of the 1990's. In 1996, 75% of the refinery's shares were transferred to Nafta Polska S.A. (a state-owned holding company for the Polish oil sector), 25% remained in the hands of the Polish State Treasury. After the transfer of

14.99% of the Treasury's pool to the refinery's employees during 1998, the Treasury's stake was reduced to 10.1%. Since then, there have been various proposals and further attempts to privatise GL. The first step, following the change in plans to consolidate the company with PKN Orlen, was finding a foreign strategic investor. Among the interested candidates (Conoco, Neste, Rotch Energy) none of them proposed a satisfactory price. [Gacek, 2003]

In the meantime the company's financial situation improved and it was partly privatised through the Warsaw Stock Exchange resulting in the following shareholding structure. [BRE Bank, 2005]

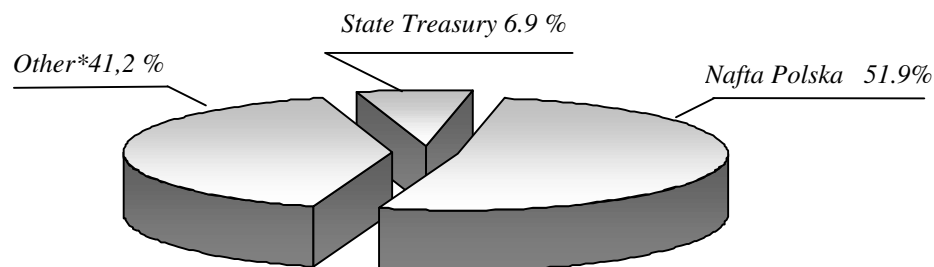

Figure 2.1: Shareholding structure of Grupa Lotos [BRE Bank, 2005]

Initial Public Offering of GL was carried out in June 2005 and consisted of the existing series A shares - 10,38% sold by Nafta Polska (the Selling Shareholder in the Sale Offering) and B-series shares - 30,78% issued by GL (the Company in the Public Subscription). The series B shares were offered in the Retail Offering and in the Institutional Offering. The Sale Offering of series A shares were conducted in the Institutional offering only. The funds being raised from series B shares have been required for the implementation of GL's investment plans. [BRE Bank, 2005]

The State Treasury maintained a decisive influence on the company and owns a 59% stake (directly and indirectly through Nafta Polska). It is likely that the controlling stake of GL will eventually end up in the hands of a strategic investor. [BRE Bank, 2005]

### 2.1.3. Organisational structure

The activity of individual companies of GL is divided into production, trade and service activity as well as exploration-production activity. The area of interests of individual companies is presented in the table below. For more information see Appendix A.

Business profile	Company
Exploration & production	Petrobaltic
Sales & logistics	LOTOS Paliwa, LOTOS Partner, LOTOS Oil, LOTOS Mazowsze, LOTOS Asphalt, LOTOS Kolej, LOTOS Parafiny
Production & services	LOTOS Ekoenergia, LOTOS Serwis, LOTOS Lab, LOTOS Straż, LOTOS Ochrona, Refineries in Gdańsk, Czechowice and Jasło

Table 2.1: Business structure of Grupa LOTOS [GL, 2005]

In February 2005, GL acquired shares under the agreement concluded between Nafta Polska and GL, concerning the sale of all shares held by Nafta Polska in Oil & Gas Exploration-Production Company- Petrobaltic (69.00%) as well as Czechowice Refinery (80.04%), Jasło Refinery (80.01%), Glimar Refinery (91.54%; in January 2005 being declared bankrupt). Acquisition of the holdings in Petrobaltic, was only possible if GL also purchased the stakes in the southern refineries. These refineries do not process sufficient quantities of petroleum and are too inefficient to remain on the market. The strategy adopted for them involves transforming their activity and ceasing the processing of petroleum. [GL, 2005]

The transaction complies with the Government Strategy for the Oil Industry in Poland, of September 2002, designed to increase the value of assets held by the Treasury in the companies in the petroleum sector to reinforce their market position. [MSP, 2003]

On December 2004 GL employed 798 persons compared to 961 a year earlier. This reduction is a consequence of restructuring. However the size of workforce in GL together with its subsidiary companies grew from 2323 at the end of 2003 to 3365 a year later. These increases were largely due to integration with the southern refineries (around 500 employees) and because of the newly created subsidiaries. [GL, 2004a]

## **2.2. The core of GL**

The core of GL is the second largest oil refinery in Poland located in Baltic seaport of Gdańsk. The refinery occupies the area of approximately 300 hectares, 70 % of which is covered by a park of tanks storing raw materials, semi-products and final products. [GL 2004/2005]

### **2.2.1. Raw material procurement**

The main raw material, crude oil, supplied to the Gdańsk refinery primarily originates from deposits in Russia. GL currently processes petroleum mainly comprised (more than 90%) of Ural crude oil and a small amount (5%) of sweet Rozewie crude, drilled by Petrobaltic from the Baltic Sea. In addition, other feedstocks, such as vacuum gas oil and fractions of gas oils are refined. [BRE Bank, 2005; GL, 2003]

The Russian oil is supplied to the refinery by the Friendship Pipeline, which plays a key role in supplying crude to Polish refineries, transporting Russian crude to Polish (at Gdańsk and Płock) and German (at Leuna and Schwedt) refineries. There is the alternative possibility of importing oil by sea due to the direct access of GL to the trans-shipping terminals at Naftoport and Port Północny. [BRE Bank, 2005]

Currently the company does not foresee changes in the origin of the raw material. To offset the effects of possible disruption (in January 2005, one of the suppliers suspended its deliveries of the Russian oil to Polish refineries) that could have a negative influence on

the activity of GL, the company launched a special programme providing for purchase oil from other sources, using the currently operating infrastructure. [Zgoda et al.,2005]

### 2.2.2. The current GL's refinery configuration

Three core technological units currently operate in the Gdansk refinery [GL, 2004/2005]:

- The fuel block, with an annual processing capacity of 6 Mt of petroleum. Main products from the fuel unit include: gasoline, jet fuel, diesel fuel/gasoil.
- The oil block with an annual production capacity of 250 thousand tonnes. Main products from the oil unit include base oils and waxes, HFO and bitumen/asphalt.
- The hydrocracking complex processing heavy petroleum fractions, with an annual production capacity of 1.4 million tonnes.

Both of the fuel and oil blocks began operating during the initial phase of the refinery's activity in 1975, while the hydrocracking complex was added in 2000. [GL, 2000]

The following figure presents the simplified scheme of the existing GL refinery complex which including the units operating in the fuel oil block, oil block and hydrocracking complex.

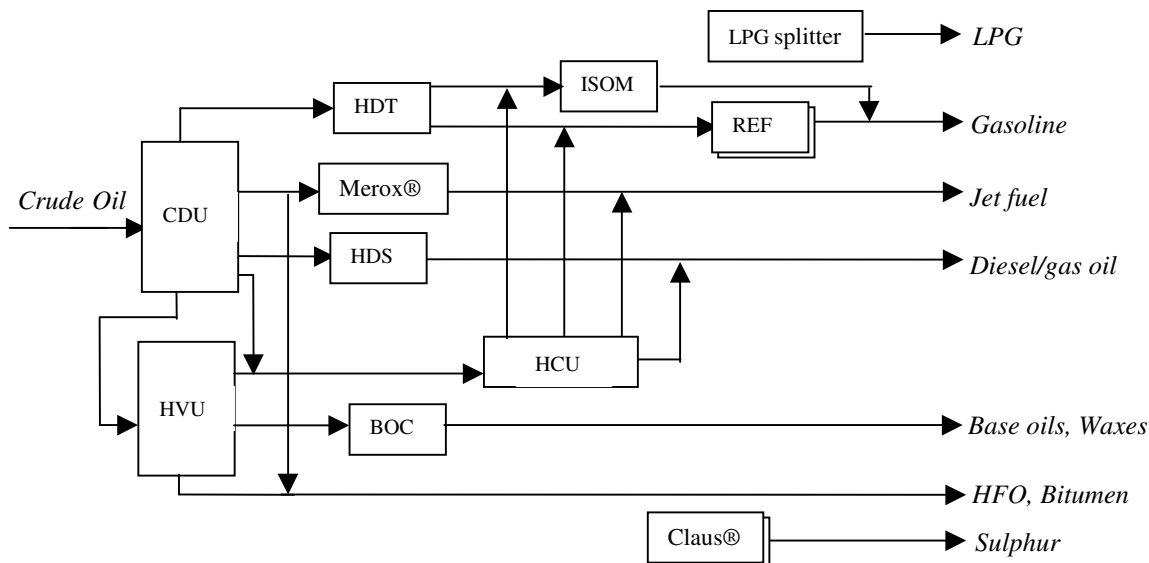

Figure 2.2: Simplified scheme of the existing GL refinery complex [GL, 2004/2005]

#### The fuel block

Crude oil feedstock coming to the Gdańsk refinery is first pumped into the Crude Distillation Unit (CDU). Crude oil is heated to the elevation temperatures and then generally subjected to distillation under atmospheric pressure which separate the various fractions according to their boiling point. Products isolated from crude by simple distillation are straight-run gasoline (also called naphtha), kerosene and gas oils/diesel fuel.



These straight-run products are drawn off at successively lower positions in the column. Hydrocarbons with boiling point higher than gas oil/diesel fuel are not vaporised but remain in liquid form and fall to the bottom of the column. These are called atmospheric residues (AR). [GL, 2004/2005]

Straight-run heavy naphtha stream from the CDU is mixed with the hydrogen-rich gas stream and catalysts in the hydrotreater (HDT) to remove sulphur, nitrogen and metallic contaminants. The heavy naphtha leaving HDT is a very poor gasoline blend component so before using it as a gasoline blendstock it is upgraded in two reformers and isomeration unit. Reforming process rearranges hydrocarbon molecules in the naphtha thereby converting paraffinic and naphthenic type hydrocarbons into aromatic type hydrocarbons, suitable for blending into finished gasoline. The hydrogen by-product from the reforming process is essential ingredient for hydrocracking unit (HCU), hydrodesulphurisation (HDS) and hydrotreating processes and is generated when liquefied petroleum gas (LPG) produced during reforming, undergoes a steam reforming process. During isomeration process, burning characteristics (octane number) of paraffins are improved. [GL, 2004/2005]

Straight-run kerosene is treated in a Merox® unit to produce jet fuel. The patented process name of Merox is a sweetening process, which includes mercaptans (a form of sulphur compound) removal by oxidation. Jet fuel should be free of mercaptans because otherwise it emits foul odour on burning. Straight run gasoil/diesel fuel undergoes HDS process in order to arrive at the required sulphur specifications. [GL, 2004/2005]

### **The oil block**

When atmospheric bottoms/residues reach a High Vacuum Unit (HVU), they are distilled under reduced pressure (less than atmospheric) to increase volatilisation and separation. Vacuum distillation lowers the boiling temperature of the liquid being distilled permitting the production of distillates at lower temperature than would be necessary in atmospheric distillation. The products from the HVU are heavy vacuum gasoil, vacuum residue (VR) and waxy distillates. [GL, 2004/2005]

Vacuum gasoils are furthered processed in the HCU while the waxy distillates side-stream is used as a feedstock for the base oil complex (BOC) to produce base oils (lubricating oils) and waxes. The heaviest fractions of the petroleum processing residuals referred to as VR, often called "bottom of the barrel" is blended to produce bitumen and HFO. The pure sulphur is recovered in Claus® sulphur recovery units (SRU). [GL, 2004/2005]

### **Hydrocracking complex**

Hydrocracking converts atmospheric and vacuum gasoils to lower molecular weight, sulphur free gasoil components, which are blended with desulphurised straight-run gasoil, hydrotreated straight-run naphtha as well as straight-run kerosene for producing increased yield of diesel oil and industrial gasoil grades, gasoline, jet fuel and LPG. [GL, 2004/2005]

### **2.2.3. Description of the main products offered by GL**

#### **Gasoline**

GL mainly produces and sells the following types of gasoline: 95 RON unleaded gasoline, 95 RON AL gasoline and 98 unleaded gasoline. Gasoline produced by GL either meets or exceeds EU requirements. In the first quarter of 2000, GL was the first refinery in Poland to totally eliminate tetraethyl lead from all its gasoline. Moreover, the sulphur content in gasoline produced by GL is among the lowest in the country, averaging at 0.001%. Such fuel will be required within the European Union after 2009. GL continues to produce universal U95 gasoline despite falling demand for this fuel. [GL, 2005]

#### **Diesel oil**

Diesel oil produced by GL includes: Eurodiesel City, Eurodiesel LOTOS, Eurodiesel Eko, IZ 40 diesel oil and F-75 marine fuel. In 2000, the Company introduced a diesel oil onto the market with exceptionally low sulphur content (50 ppm). Sulphur content at this level was required in the European Union from 2005. Moreover, in November 2003, GL was the first oil company in Poland to introduce a new super ecological diesel oil with sulphur content of 10ppm this time meeting EU requirements that will enter into force in 2009. [GL, 2005]

#### **Light fuel oil**

GL produces and sells the following brands of light fuel oil (applied as heating oil in households): RG TERM 0,2, 0,1 light heating oil and LOTOS RED. The new generation LOTOS RED fuel oil with a maximum sulphur content of 0.1% (introduced in 2003) ensures improved burning and increased furnace efficiency. The product won the Grand Prix at the International Oil and Gas Trade Fair in 2003. Sales of RG TERM 0,2 fuel oil will gradually be discontinued due to its sulphur content. [GL, 2005]

#### **HFO**

The majority of vacuum residue currently produced is sold in the form of HFO (sulphur content averaging 2.6%) and as a raw material or intermediate product for further processing. The remaining quantities are used for bitumen production. The EU legislative changes regarding the possible use of HFO on both land and sea will mean that the market for this product and the margins achieved on its sale will decline. Therefore GL aims to eliminate production of HFO. [GL, 2005]

#### **JET A-1 Aviation Fuel**

GL is among the largest producers of JET A-1 aviation fuel in Poland, which constitutes the main export product of GL. Demand for this fuel (applied in jet engines) is high due to a significant deficit on European markets. [GL, 2005]

### Base oils

Currently, GL produces base oils, a proportion of which is used by LOTOS Oil for production of lubricating oil, while surpluses are sold to Polish and foreign lubricating oil producers. LOTOS Oil is among the leading producers of lubricating oils and lubricants in Poland and is the market leader in the engine oil segment. Production of lubricating oils was transferred from GL to LOTOS Oil at the beginning of 2004. [GL, 2005]

### Bitumen components

GL produces bitumen components for its subsidiary company - LOTOS Asphalt, which has been engaged in the production and sales of bitumen (previously offered by GL) since April 2004. LOTOS Asphalt is the domestic market leader in production of modified bitumen products. [GL, 2005]

### Liquid gases

The liquid gases produced by GL include technical propane (among other applied to heat and cut metal), liquid gas (applied as a fuel in spark-ignition engines and for heating households) and technical butane. [GL, 2005]

### Other refinery products

Other refinery products manufactured by GL include slack wax (used as the main raw material for production of paraffin by LOTOS Parafiny), oil plasticisers (applied in the rubber industry as a softening agent) and sulphur (used for specialist applications, among other as material to produce sulphuric acid). [GL, 2005]

## 2.2.4. Sales structure of the main products offered by GL

The breakdown of product sales of GL by volume and value is presented below.

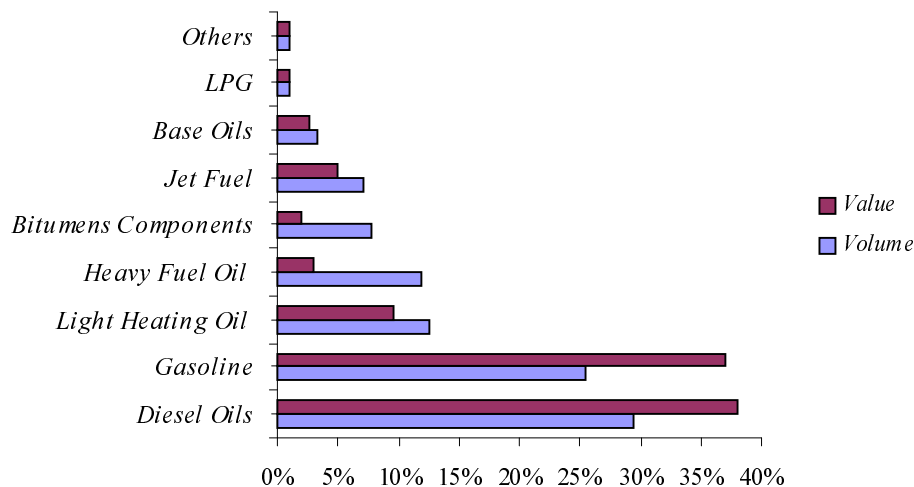

Figure 2.3: The breakdown of product sales of GL by volume and value in 2004 [GL, 2005]

As can be noted in volume terms the sales structure is dominated by diesel oils, gasoline, light heating oil and heavy fuel oil. However an analysis of revenues shows slightly

different hierarchy where HFO and bitumen components yield little profit in the overall sales structure. Products yielding the highest profit include transport fuels. This is due to the fact that they dominate in the volume as well as they are characterised by highest margins.

### **2.2.5. Key sales markets of GL**

The dominant direction of GL sales is the domestic market. Although fuels produced by GL find customers in Western Europe due to their quality and environmental attributes, the higher profitability of sales on the Polish market means that it is precisely this direction that GL intends concentrating on. [GL, 2005]

Domestic product sales are generated based on road (road tankers) and rail transport (rail tankers). As a result of the recent reorganisation of sales structures within GL, the main distribution channels for refinery products have become trading and combined production and trading companies created on the basis of assets of GL. [GL, 2005]

GL is using outside channels of distribution to an increasingly smaller degree. In this way, it is increasing the share of company-owned channels and therefore the company's share in the wholesale fuels market in Poland. This share has grown from 14 to 21.3% in the last 3 years, with a strategic goal of 30% in 2010. [GL, 2005]

GL plans to obtain a 12% share on the retail fuel market in 2010 (from the current 6%). This will be realised under the Petrol Station Network Development Programme (PROSTA) which assumes increasing the number of petrol stations up to 500 from the current 352 as well as increasing the average annual volume of fuel sold per station. (PROSTA is further described in the Appendix B of this report). Due to strong competition on the retail fuel market in Poland there can be no assurance that this objective will be achieved. [BRE Bank, 2005]

The retail fuel market in Central and Eastern Europe is significantly influenced by the actions of Russian oil companies, which are the main suppliers of raw material to local companies. Russian companies are showing interest in co-operating with and investing in Central European oil companies. Competition may also increase as a result of the development of service station networks by hypermarkets, which offer significantly lower prices than the remaining operators on the retail fuel sales market. Due to PKN Orlen acquiring 62.99% of the Czech Oil Company Unipetrol, the risk exists that PKN Orlen will strengthen its position by enlarging its market and expanding its distribution network. [GL, 2005]

The most important, external clients of GL products on the domestic market are Statoil, BP as well as PKN Orlen and Pol-Oil-Co (wholesalers and the network of petrol stations). GL has a signed agreement with PKN Orlen involving the exchange of fuels in various regions of Poland. [BRE Bank, 2005]

The main export products of GL are: JET A-1 aviation fuel, unleaded 95 RON gasoline, HFO and base oils. The main directions of JET A-1 aviation fuel sales are Sweden, Denmark, Great Britain and Norway. Unleaded 95 RON gasoline is mainly exported to the Netherlands, Sweden and Great Britain, while HFO is used mainly as a component for bunker fuel at ports in Denmark and Norway and to a lesser degree the Netherlands. Base oils are mainly exported to Belgium, as well as Sweden, Germany, France and Austria. [GL, 2005]

GL mainly exports its products by sea. Products are supplied to Port Północny in Gdańsk by the product pipeline owned by GL. Two companies operate at the port, Naftoport and Port Północny, which are both engaged in handling refinery products, among other for GL. [GL, 2005]

### **2.2.6. Other information**

GL implemented and certified an Integrated IT System in 2003 encompassing requirements of the following systems: ISO 9001 quality management, ISO 14001 environmental management, PN-N-18001 safety and work hygiene management systems and an Internal Control System. In 2004, the company upgraded the atmospheric monitoring stations around the Gdańsk refinery. [GL, 2003; GL 2004a]

GL has won numerous awards and distinctions. The most significant include [GL, 2005, GL 2003]:

- Leader of Polish Business Statuette awarded by the Business Center Club in 1993 (in 2004, GL received its sixth diamond as part of this distinction),
- The Wektor Prize, for innovative solutions recommended as models to be imitated, was awarded in 2004 by the Confederation of Polish Employers; GL received the prize for bringing the complex restructuring process of the Company to a successful conclusion,
- The “Environmentally Friendly Company” title awarded in 2003 as part of the IV “Friends of the Environment” Ecological Competition. The title is recognised as the most prestigious distinction

## **2.3. Development plans of GL**

Processing the relatively cheap Russian oil results in the necessity to build installations, which process heavy petroleum residuals. In addition, high petroleum prices as well as the differing prices of heating oil and motor fuels, result in the refinery's efforts to maximise production of diesel fuel and simultaneously limit the yields of heavy products.

Thanks to the refinery investment programme (1996-2000) including a hydrocracking complex and an isomeration unit GL became one of the leading Europe's up-to-date

refineries. The essential factors relate to high quality of unleaded petrol production and reduction of benzene and sulphur level. [GL, 2002]

According to the Wood MacKenzie ranking in 2001, which covered 112 refineries in Western and Central Europe, GLSA was classified on 37<sup>th</sup> place in terms of complexity and 6<sup>th</sup> place among refineries that have been most successful in desulphurisation of their products. [GL, 2002]

Thanks to the hydrocracking installation GL is capable to produce gasoline and diesel with the sulphur content obliging only from 2009. [GL, 2003]

However, the degree of conversion of heavy oil processing residuals has not been that advanced.

The main product now manufactured from heavy residues is low value bitumen and HFO with high sulphur content. HFO has been produced mainly for export and used on site as a fuel for generating of heat, electricity and steam in furnaces and boilers.

Due to sulphur emission constraints GL can no longer burn high sulphur fuel oil (HSFO) as the marginal fuel. At the moment refinery is mixing HSFO with a more expensive diesel oil/gas oil attempting to maximise the use of HSFO within the limits of the permitted sulphur emission level of 3500 mg/ Nm<sup>3</sup>. However when the maximum emission value total sulphur limit of 1700mg/Nm<sup>3</sup> is reached (legally binding for Poland from January 2007) sulphur content in heavy fuel oil must equate to 1%. Thus the refinery will have to burn greater amounts of gas oil. As a result, the cost of the marginal mixed fuel will become even higher than the cost of the refinery's highest cost fuel. [GL, 2004/2005; Zgoda et al., 2005]

Currently HFO accounts for 12% of total GL' production while the revenue yields very little profit (3%).

In order to meet the emission legislation and growing demand for cleaner refinery products GL has to maximally reduce HFO production and find a new source for generation of heat, electricity and steam in its furnaces and boilers. [GL, 2004/2005]

To operate in more efficient and environmentally friendly manner while meeting the growing demand for cleaner refinery products, GL has developed Residue Upgrading Project for its refinery in Gdańsk.

The RUP involves an investment in a complex of three mutually inter-related installations. The major element of the project is the construction of a plant complex for gasification of heavy residuals from petroleum processing - Integrated Gasification Combined Cycle (IGCC). The technology is a clean and efficient process for converting very heavy residues

into synthesis gas (syngas), which can be used to produce hydrogen or/and as a clean fuel for power generation. The RUP will also employ solvent deasphalting (SDA) and mild hydrocracking (MHC) technology. [GL, 2004/2005]

This is the most important and most capital-intensive investment planned by GL. The value of the RUP is estimated at approx. USD 800 million. For comparison, the value of GL previous major investments was approximately USD 85 million for catalytic reforming, launched in 1995, and approximately USD 430 million for the hydrocracking unit in 2000. [Zgoda et al., 2005]

The RUP is further described in the following chapter.

### **3. Background information of the RUP**

This chapter provides background information of the RUP. It describes the core technologies used within the framework of the RUP and depicts their flow. Basic information on the technologies licensors is also provided and how the project will be financed. GL's refinery configuration together with the new product mix after implementation of the RUP is presented followed by the benefits which the execution of the RUP will bring to GL.

#### **3.1. The core technologies and their licensors**

A unique and significant characteristic of the RUP is the concept to combine the use of three different, modern technologies [GL, 2004/2005]:

- A solvent deasphalting unit based on residual supercritical extraction technology (ROSE™ - licensed by Kellogg Brown & Root), which separates valuable lighter products from the heavy residue using the differing solubilities of the components. Main products include thickened and polluted residues (asphaltene) and deasphalted oil (DAO). This licensor has been chosen as the technology has a very good record noted in the oil industry. It has been commercially practised since the 1979 and has been installed in 30 refineries
- A world-scale Mild Hydrocracker based on Shell Global Solutions licensed technology, allowing production of high quality fuels from intermediate product (DAO) obtained in the ROSE unit.
- Integrated Gasification Combined Cycle technology to create a production complex comprised of gasification unit and cogeneration power plant where syngas is produced from the thickened and polluted residues (asphaltene). When the impurities are removed part of this syngas is used to obtain hydrogen while the remaining is used to generate electricity and heat (process steam). The technology is based on Shell Global Solutions as it is a world leader in the development design and construction as well as in the detailed engineering, commissioning, start-up and operation of gasification technologies.

In building and operating its own installation, GL will be advised precisely by Shell Global Solutions as well as Kellogg Brown & Root. These two companies will share the rights to the IGCC, MHC and ROSE installations. GL has signed conditional licensing agreements and an agreement involving support and technical supervision with the mentioned companies. [Zgoda et al., 2005]



Apart from constructing new units (IGCC, MHC, ROSE), the development of infrastructure and auxiliary facilities will be necessary to allow to increase the depth of crude processing and additionally process 1.5-2m tons of vacuum and/or atmospheric residue from crude distillation. [GL, 2004/2005]

### 3.1.1. The RUP flow description

The following figure presents a simplified block flow diagram of the new units.

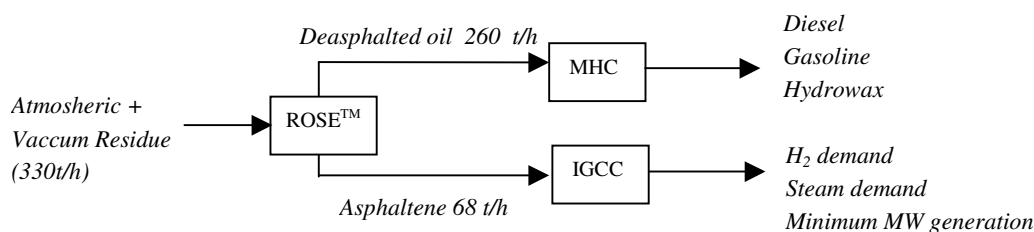

Figure 3.1: A simplified block flow diagram of the new units [GL, 2004/2005]

At a nominal throughput of 330 t/hr SDA unit will use a blend of vacuum and atmospheric residue (VR+AR) as a feedstock. Solvent deasphalting involves contacting of a heavy residue stream with a lighter hydrocarbon solvent in order to recover valuable DAO with dramatically improved quality. The process rejects highly aromatic, condensed asphaltenic molecules, which normally contain substantial quantities of metals, sulphur and nitrogen. [GL, 2004/2005]

68 t/hr of asphaltene high in metals and sulphur, having zero or negative value will be a feedstock for the IGCC. In this plant it will be gasified to produce syngas used for production of hydrogen (216t/d) and steam for refinery needs and small quantities of electricity (balance to 44 Mwe and 72 Mwth). [GL, 2004/2005] This process is explained in more detail in the following subchapter

260 t/hr of DAO will be further processed (mixed with 6.5 t/hr of hydrogen, pumped to operating pressure and heated) in the hydrocracker unit. The MHC unit will convert DAO into lower-molecular-weight products such as naphtha, kerosene, diesel and hydrowax – desulphurised oil, which can be sold as a fluid catalytic cracking feedstock for manufacture 10 ppm sulphur gasoline without further post-treatment or as a low sulphur component for a fuel oil pool. [GL, 2004/2005]

### Integrated Gasification Combined Cycle

As mentioned before IGCC has two basic components a gasification unit and a cogeneration power plant with two gas turbines and two steam-turbine generators. The asphaltene stream is fed to the gasifier where it reacts with steam and oxygen (oxygen delivered from an air separation unit - ASU) at high temperature and pressure in a reducing

(oxygen starved) atmosphere. The product of the partial oxidation (raw syngas) containing particles of soot and metal ashes is cooled in the syngas effluent cooler. The heat recovered is used to produce high-pressure steam. Particles of soot and metal ashes are removed from the system as soot–water slurry in a two-stage water scrubber. In a Soot Ash Removal Unit (SARU), soot and ash are removed from the slurry and valuable metals such vanadium and nickel are recovered. [GL, 2004/2005]

After passing through a cooler and a scrubber the gas has a residual soot content of less than 1 mg/m<sup>3</sup> suitable for feeding to the desulphurisation unit. The hydrogen sulphide removed from the syngas will be processed in the refinery's Claus plants (sulphur recovery units) to produce pure sulphur. [GL, 2004/2005]

Most of the desulphurised syngas (made up primarily of carbon monoxide and hydrogen and smaller quantities of carbon dioxide and methane) will be used to manufacture hydrogen. The plant produces the pure hydrogen, which is fed to a common hydrogen network. Steam production will be in line with the net demand of the integrated refinery complex. It will cover the process needs of the gasification section, the power block and the existing refinery facilities. The excess desulphurised syngas will be fed as a clean fuel to the gas turbines of the power block to produce electricity for the refinery. [GL, 2004/2005]

The following presents the simplified block flow diagram of the IGCC.

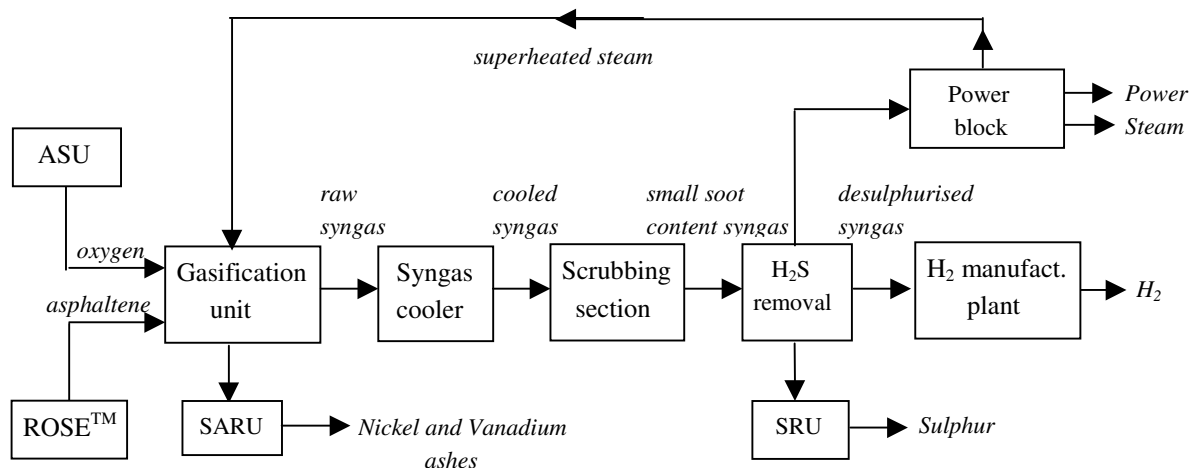

Figure 3.2: Simplified block flow diagram of the IGCC [GL, 2004/2005]

The IGCC is has been among techniques to consider in the determination of Best Available Technique (BAT) in energy production as stated in the Integrated Pollution Prevention Control (IPPC) Directive reference document. [EIPPCB, 2003]. Also the EU's Green

Paper on the promotion of renewable sources of energy recommends IGCC installations [EC, 2000].

### **3.2. Project financing**

In order to conduct this capital-intensive investment, GL established the company LOTOS Ekoenergia (LESA) - a wholly owned GL subsidiary, which will finance, build and operate the new installations. According to GL's plans, GL investments in RUP will correspond to 10% of the value of the investment, while the remaining funds will be supplied by LESA (company funds and bank loans). Funds obtained from the issue of shares have been used to increase the equity of LESA. GL will be able to finance about 35% of the investment independently, in order to limit the risk connected with outside financing, it has already begun negotiations with the following entities, which are to provide the financing. [Zgoda et al., 2005; GL, 2005]

*The European Bank for Reconstruction and Development (EBRD).* The EBRD uses its close relationship with governments in the region to promote policies that will support the business environment. It provides project financing for banks, industries and businesses, both new ventures and investments in existing companies. EBRD has declared concerning a capital engagement in the RUP for an amount constituting 20% of total capital expenditure (up to USD 40 million) and credit up to USD 170 million. [EBRD, 2005; Zgoda et al., 2005]

*Bank Ochrony Środowiska (BOŚ) (Environmental Protection Bank)* is a universal commercial bank and at the same time a bank specialised in financial support to investment undertakings in environmental protection, co-operates closely with regional voivodship funds for environmental protection. BOŚ has signed an agreement with LESA aimed at arranging finance for the part of RUP directly connected with environmental protection (approx. USD 20 million) [BOŚ, 2003; Zgoda et al., 2005]

*European Investment Bank (EIB)* the EU's financing institution raising on the markets substantial volumes of funds which it directs on the most favourable terms towards financing capital projects according with the objectives of the Union. EIB have signed a letter of intent with LESA, expressing its interest in financing up to 50% of the value of the RUP, with a long-term loan (of up to 16 years). [EIB, 2005; Zgoda et al., 2005]

In December 2002 Polish Government decided to buy 48 F-16s from - Lockheed Martin (American defence contractor and aerospace manufacturer) worth USD 3,5 billion. As a part of the sale, the company agreed to offset projects valued more than USD 6 billion in Poland. GL project will be included in the offset programme. Lockheed Martin will finance license fees (USD 15 million) for IGCC, ROSE and MHC technologies. [USE, 2003; Zgoda et al., 2005]

### **3.3. GL after implementation of the RUP**

The RUP envisages processing heavy residue from Urals crude refined at the Gdańsk refinery and additional imports of 1.5-1.8 Mt p.a. of residues from other source. This is because the amount of residue from the petroleum processed at the Gdansk refinery is not sufficient to ensure the full efficiency of the new units. The natural supplier appears to be PKN Orlen, but the companies have not yet come to an agreement concerning the RUP. Current analyses assume that the charge will originate from refineries processing heavy crude oil in countries of the former Soviet Union and will be imported by sea, which is favourable supply route for GL. [BRE Bank, 2005]

Atmospheric residue is a by-product of the refining processes that have been usually sold as a component for HFO or bunker fuel oil.

Most of the imported atmospheric residue currently sold in Northwest Europe is supplied from Russia. There are two main reasons for this export flow. Russian refineries typically have lower levels of upgrading than Western European sites and limitation in logistics in exporting crude oil have given Russian refineries an incentive to maintain high throughput levels resulting in large amounts of atmospheric residue. [Nexant, 2004]

Due to declining market for HFO there is a risk that demand for atmospheric residue in the EU will decline at the same time lowering its price. This in turn may cause a shift of Russian exports to more attractive Asian markets. [GL, 2004/2005]

However according to Nexant Chem Systems (a renowned refining industry advisor specialising in market analyses and project assessment) these exports should continue although may decline. [Nexant, 2004]

GL assumes that demand for raw materials for the new units built within the framework of the RUP, will be supplemented by imports during the initial years of operation. During this period, refining units at Gdańsk used to prepare charge material could be expanded to levels that would allow additional processing of crude oil to ensure raw materials for the planned units. In such a situation, GL would be able cease imports of heavy charge and replace it with crude that would allow to ensure full supply of the RUP units with its own charge. [Zgoda et al., 2005]

After the RUP installations go online in 2009, the total volume of products will be lower than the quantity of processed oil. This is due to the fact that the entire charge for the gasification installation (approximately 570 thousand tonnes annually) will be converted into thermal energy and hydrogen needed for processing the increased quantity of the input. In addition, future greater demand for electricity will be covered with the company's own production. [GL, 2004/2005]

### 3.3.1. GL's refinery configuration and products after 2009

Currently, GL's residue is used to produce heavy heating oils and asphalts. As sales of heavy heating oil will be limited beginning in 2007, due to environmental reasons, GL plans to completely eliminate this product from its assortment. In the 2007-2008 period, GL will use vacuum residue to produce asphalts and bunker fuel, while the remainder (including heavy heating oil) will be sold as input for other refineries. After 2009, asphalts will still be produced, but their annual share in production will not exceed 200 thousand tonnes (according to current plans, the size of production will actually be approximately 100 thousand tonnes). GL is still considering the possibility and profitability of base oil production. It cannot be ruled out that the production of this assortment will also be limited. [GL, 2004/2005]

The main oil products generated by units build as part of the RUP will be diesel oil (approx. 1Mt/p.a.), low sulphur residue from hydrocracking processes (approx. 0,8Mt /p.a.) and gasoline (approx. 0,5Mt/p.a.). As a result, production of heavy, high-sulphur fuel oil will be totally eliminated. [GL, 2004/2005]

The new refinery configuration together with its products is presented in the figure below.

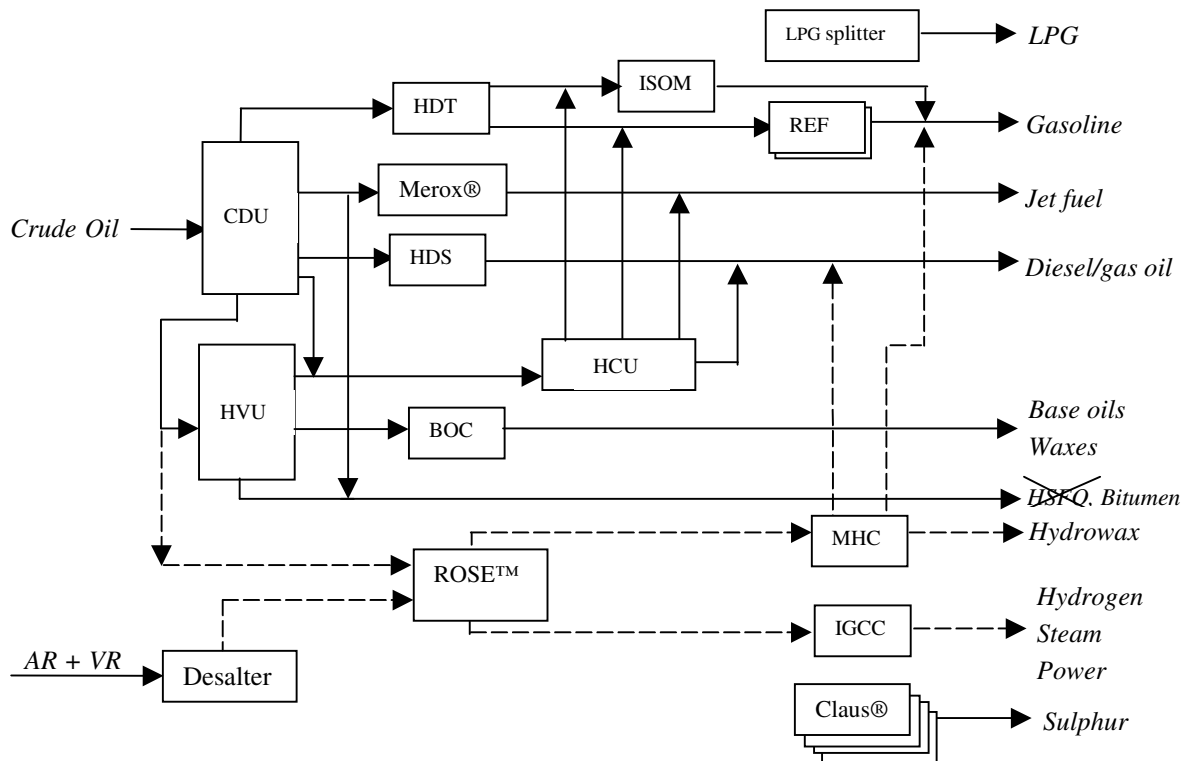

Figure 3.3: Simplified scheme of the GL refinery complex after 2009 [GL, 2004/2005]

After RUP's installations go online GL's production structure will change to include high quality products, which will match the trends on the consumer markets in Poland and in Western Europe.

Forecasts prepared by Nexant Chem Systems assume the following [Nexant, 2004]:

- Average annual growth of the domestic market in the next few years to run at approx. 2% for gasoline and approx. 3% for diesel oil.
- Surplus in gasoline in the north-west Europe region but in contrast deficit in diesel / gas oil, particularly in low sulphur grades of diesel. Deficit for diesel / gas oil is likely to be maintained and therefore there will continue to be outlets for in the region for these material.
- MHC residue (hydrowax) is a high quality feed for fluid catalytic cracking conversion units. The total demand for fluid catalytic cracking feed in north-west Europe is currently around 60Mt per year, of which 5Mt is imported, typically in the form of atmospheric residue. MHC residue will be particularly attractive because of its low sulphur content, which will allow refiners to process more sour crude slates while meeting end-product sulphur limits.

Given the above, no difficulties with marketing products generated by the new units should be expected.

However, to minimise the risk involved, products from the RUP units have been covered by long-term supply contracts with Shell International Trading and Shipping Company (STASCO), constituting security against repayment of loans to banks. STASCO undertakes to purchase RUP products (all amount of hydrowax and smaller amount of diesel oil) based on the price formula described in the contract linked to market quotations. The contracts start from the moment of RUP units becoming operational. [Zgoda et al., 2005]

### **3.4. Benefits of the RUP**

Execution of the RUP will bring GL both environmental and economic benefits.

#### **3.4.1. Environmental benefits**

The gasification process with integrated power block will result in improvement in emission levels and there will be a significant reduction in the impact of the GL's refinery and its products on the environment. Refinery SO<sub>2</sub> emissions will be substantially reduced through the replacement of high-sulphur fuels with desulphurised syngas as feedstock for utility generation and secondary SO<sub>2</sub> emissions will be reduced thanks to discontinuing production and consumption of high-sulphur, heavy fuel oil. In addition more effective generation of heat and electricity than in conventional power stations will allow for less CO<sub>2</sub> emissions per unit of electric power produced [EIPPCB, 2003]. [Zgoda et al., 2005]

### **3.4.2. Economic benefits**

The economics of RUP are based on the conversion of heavy residue from crude refining, which is of a low market value and high burden on the environment, into the form of purified white products and environmentally generated power and process gases, which have a significantly higher market value. [Nexant, 2004]

The price of 1 tonne of product currently manufactured from the residue is low in relation to the costs of 1 tonne crude oil. However, in the case of products that the refinery will manufacture following the completion of the RUP, this price will exceed the cost of oil. [Nexant, 2004]

The refining margin of GL are affected by changes to the price finished products compared to crude oil prices. Crude oil is the main raw material GL uses in its production activities. Prices of crude worldwide are subject to significant fluctuations resulting from changes in the global demand for and supply of crude oil and political situation. GL purchases crude at prices linked to the price of crude oil on international markets. Prices of oil products offered by GL depend on the prices quoted on exchanges worldwide. [GL, 2005]

Prices of oil are currently above average. Economic growth, and particularly demand from China, permanently raised the price of oil from less than USD 20 per barrel in the 1990's to a current level of above USD 50. In 2004, the average price of Brent oil exceeded USD 38 per bbl. [BRE Bank, 2005]

In the forecasts it is assumed that the currently high prices of oil are a temporary phenomenon and that both the demand for oil and its prices will stabilise in the years ahead. [BRE Bank, 2005]

Management Board of GL assume that, with oil prices of USD 20-25 bbl of Russian crude the additional margin including variable costs generated after completion of the investment will amount to USD 205 million. [Zgoda et al., 2005]

## 4. Theories & methods

This chapter presents the discussion and choices of the theories and the concepts to be applied in the analyses. Then follows the delimitation of the field to be studied along with clarification of research questions as well as how the analyses have been structured. The chapter ends with a discussion of data collection methods used in the report.

### 4.1. Programme evaluations

At the present time there is no general Theory of Evaluation totally developed and common to all the disciplines and areas of knowledge in which the evaluation is applied. On the contrary, there are diverse theories of programme evaluation, each one focused on specific method applied according to the field to be studied and the purpose of evaluation. [Lopez, 2000]

In this report the object being evaluated is GL's residue-upgrading project and for this reason term 'project' instead of 'programme' will be used in further reading.

The evaluation approach used in this report is based on the "evaluation" definition recommended by Organisation for Economic Co-operation and Development (OECD) through its Development Assistance Committee and adopted by all major donor agencies internationally [OECD, 2002; DANIDA, 1999; EC, 2004c; JICA, 2004]:

*An evaluation is a systematic assessment of a planned, ongoing or completed intervention to determine its relevance, efficiency, effectiveness, impact and sustainability. The intent is to incorporate lessons learnt into the decision making process.*

The definition stipulates five specific evaluation criteria that should be used in assessing development interventions. Taken together, these five criteria used in combination should provide the decision-maker with the essential information and clues to make correct diagnosis and determine what should be done next.

Evaluation also refers to the process of determining the worth or significance of an activity. [OECD, 2002]

A common distinction in evaluation character is that between formative and summative evaluation [Robson 2002; AROW, 2004a; AROW, 2004b]:

- 'Formative evaluation' (improvement) is typically conducted to improve or strengthen a project being evaluated during its development or implementation phase. The results need to be reported on in time for modifications to be made as a result of the evaluation. The evaluation is conducted for the benefit of those



managing the project with their participation and with focus on improving their work.

- 'Summative evaluation' (judgment) is conducted after the impact of the project has had a chance to be realised. The evaluation is likely to cover the total impact of the project, not only the extent to which stated goals are achieved, but also all the consequences that can be detected. The evaluation is mainly for the benefit of external stakeholders often for reasons of applicability to similar projects.

Although formative evaluation is commonly contrasted with summative evaluation, the distinction is not absolute. The process of formative evaluation may be an important component in summative evaluation in order to determine why the project did or did not work. Summative evaluation could also have a formative effect on future project. [Robson 2002; EVALSED, 2005a].

### Evaluation criteria

The following table presents a brief description of each of the Five Evaluation Criteria.

Relevance	A criterion for considering the validity and necessity of a project regarding whether a project intervention is appropriate as a solution for problems concerned and whether the specific problem relates to the overall political goals or principles.
Efficiency	A criterion for considering whether the project results have been achieved at reasonable cost, i.e. how well inputs have been converted into activities in terms of quality, quantity and time, and the quantity of the results achieved.
Effectiveness	A criterion for considering whether the project has benefited the intended beneficiaries or the target society and how assumptions have affected project achievements.
Impact	A criterion for considering the effects of the project with an eye on the longer term effects including direct or indirect, positive or negative, intended or unintended
Sustainability	A criterion that examines whether the effects produced by the project have been sustained (or are likely to be sustained) after the project completion.

Table 4.1: Evaluation criteria [EC, 2004c, DANIDA 1999; OECD, 2002]

The depth and focus of the examination of each of the Five Evaluation Criteria may differ according to when an evaluation is carried out in the project cycle.

### Time dimension

In terms of the point at which the evaluation is performed, there are four kinds of evaluation [JICA, 2004; EVALSED, 2005a; EVALSED 2005b]:

- 'Ex ante evaluation' has a formative nature and takes place before the project is launched. The evaluation helps to ensure that the final project is as relevant and coherent as possible. It includes an assessment of the quality of project preparation and

design (logic and completeness of the project design). It provides information on whether development issues have been diagnosed correctly, whether the strategy and objectives proposed are relevant, whether the expected impacts are realistic, and so on. Its conclusions are intended to be integrated into the project when decisions are taken. The evaluation also provides the required foundations for monitoring and for future evaluations, by ensuring that there are explicit and, where possible, quantified objectives. Finally, it helps to ensure the transparency of decisions by allowing for a clear explanation of choices made and their expected effects. In ex ante evaluation, apart from the relevance, evaluation according to the five criteria can only be carried out based on forecasts and prospects.

- 'Mid-term evaluation' has a formative nature and is performed during the implementation of the interventions. This evaluation critically analyses the first outputs and results of interventions. Depending on the conclusions of mid-term evaluation, adjustments may be made during the project cycle to improve the project strategy. Here "relevance" and "efficiency" can be evaluated based on actual situation and performance. However "effectiveness" and "impact" can only be examined according to what is judged to be necessary and possible at the time of evaluation and that depends on the degree to which an effect has been actually produced at mid-term.
- 'Terminal evaluation' has summative nature and examines whether a project is properly producing effects at the end of the project period. Results are utilised to decide whether the project be terminated or followed up. Here examination of "relevance", "efficiency" and "effectiveness" can be based on the actual situation and performance while "impact" according to what is judged to be necessary and possible for the evaluation. "Sustainability" at this time of evaluation can be examined based on forecasts and prospects.
- 'Ex-post/post-ante evaluation' may draw on evidence from formative evaluation although their primary focus is summative. It is conducted after a certain period has passed since the completion of a project. The evaluation recapitulates and judges the entire project, particularly its "impact". Its aim is to account for the use of resources and to report on the "effectiveness" and "efficiency" of interventions and the extent to which expected effects were achieved. It focuses on factors of success or failure, and on the "sustainability" of results and impacts. At this point, all project components should be considered with a view to examining the results. This evaluation tries to draw conclusions that can be generalised and applied to similar projects.

The approach of this report is ex ante evaluation with formative purpose. The study assesses the quality of the RUP's design. The results of the evaluation could contribute to the final appraisal of the project by those managing the project or serve as a basis for modifications to improve its design. Although the realised worth of the RUP is not known yet, the evaluation examines the project values based mainly on prospects and forecasts

(only relevance can be examined based on actual situation) by looking at its plan via the Five Evaluation Criteria.

Concretely speaking, the examination is about whether an effect will really be produced when the project is implemented according to its plan, and whether the project is planned in a way that the effect can reliably be grasped and verified. Evaluation methodology used in the analyses is explained later in this chapter.

Grasping the whole picture of a project as an evaluation target is essential as it serves as basis for conducting any type of evaluation. [JICA, 2004]

When grasping the picture of the project elements and the way the project is structured the Logical Framework Approach has been utilised. In the following subchapter the concept of the LFA has been explained including its criticism and comparison with other models.

## **4.2. Logical Framework Approach**

LFA, as its name implies, is an attempt to structure the change process (project) in a logical way. The LFA applies a hypothetical means-to-end logic that allows debate on the consistency of proposed actions and establishes a framework where progress and impact can be monitored and evaluated. The means-end logic is as follows: inputs or resources are means to perform certain activities, which under certain assumptions will produce specific outputs. These outputs are means to achieve certain objectives, which again may serve to achieve wider objectives. [DANIDA, 1996]

LFA was originally developed by the United States Department of Defense, and adopted by the United States Agency for International Development in the late 1960s to improve its project planning and evaluation system. Since then, it has been adopted by many major international development agencies. These include: the UK Department for International Development (DFID), the Danish International Development Agency (DANIDA), the Norwegian Agency for Development (NORAD), the Swedish International Development Agency (SIDA), Canadian International Development Agency (CIDA), German Agency for Technical Corporation, Australian Agency for International Development (AusAID) and the European Commission. [EC, 2004c; AusAID, 2003; IDRC, 2001]

LFA has changed considerably since it was first conceived. Whereas initially the LFA was rather a tool for a standardised presentation of projects (descriptive in nature), facilitating the decision-making procedure for those approving the projects in the 1970s it became a tool for improved design of projects, turning more analytical in order to achieve more successful projects. In the 1980s and 1990s LFA expanded to become a tool for improved project design, implementation and management, maintaining its analytical focus but broadening it with communication aspects. [DANIDA, 1996]

The manner the projects are planned and executed runs according to specific sequence defined as a project cycle comprising of five progressive phases, each with defined decision making criteria and procedures [EC, 2004c].

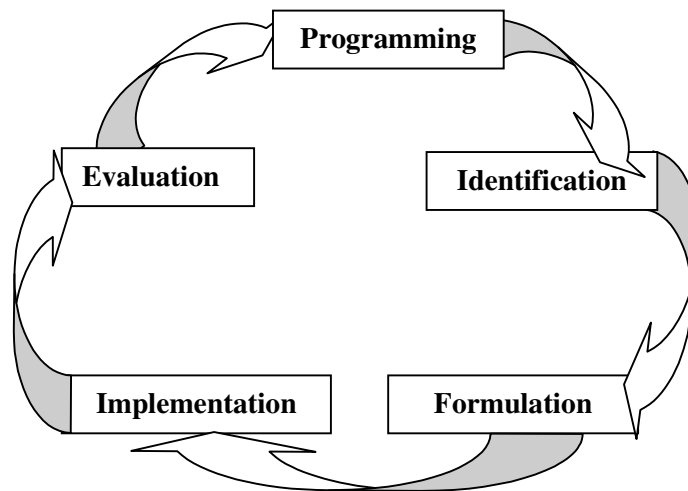

Figure 4.1: Project cycle scheme [EC, 2004c]

LFA is useful in all stages of the project cycle [DANIDA 1996; EC, 2004c]:

- In the *Identification* phase the LFA helps analyse the existing situation, investigate the relevance of the proposed project and identify the potential objectives and strategies.
- During the *Formulation* phase, the LFA supports the preparation of an appropriate project plan with clear objectives, measurable results, a risk management strategy and defined levels of management responsibility;
- During project *Implementation*, the LFA provides a key management tool to support contracting, operational work planning and monitoring; and
- During the *Evaluation* and audit phase, the LFA provides a summary record of what was planned (objectives, indicators and key assumptions), and thus provides a basis for performance and impact assessment.

What the method is used for depends on the role of its users and their needs [SIDA, 2004].

Over time, different agencies have modified the formats, terminology and tools of the LFA, however the basic analytical principles have remained the same [EC, 2004c].

The analytical process of the LFA comprises a series of steps (Stakeholder analysis, Problem analysis, Objectives analysis, Strategy analysis), which have been further explained in the following chapter.

The plan, for a particular project, developed using this process is summarised in a table that is referred to as a Logical Framework Matrix, or a Logframe which appears as destination in all versions of LFA [NORAD, 1999; EC, 2004c; DANIDA 1996; SIDA, 2004].

#### 4.2.1. Logical Framework Matrix/ Logframe

A Logframe is a way of describing a project design and serves as a summary of the key information on the project. It provides an easy overview that allows a quick assessment of the consistency and coherence of the project logic. How detailed the information is presented and the format of a matrix depends on the stage of the project and on the purpose the matrix should serve. [DANIDA, 1996]

While the Logframe shows the content of the project's composition and the logicity of its plan, it is simply an overview chart – outline table of the project plan that complies the project strategy in a four-row by four-column matrix. It does not explain all items including project background, detailed activities, the project operation structure, detailed content of technical co-operation etc. [JICA, 2004]

In this report the matrix serves as a basis for the evaluation of the RUP according to the Five Evaluation Criteria and its most basic format consisting of four columns and four rows has been adapted.

The matrix summarises what the project intends to achieve and how by displaying its composite elements ('project description' column). It sets out the causal relationship between different levels of objectives and indicates how to check whether these objectives have been achieved. At the same time, it identifies what assumptions and risks outside the scope of the project may influence its success. [SIDA, 2004; EC, 2004c; AusAID, 2003]

The table below shows the structure of the matrix together with its main elements and indicates the general sequence for completing its component parts.

<i>Project Description</i>	<i>Objectively Verifiable Indicators (OVIs)</i>	<i>Means of Verification (MOVs)</i>	<i>Assumptions</i>
1. Overall objective	8. Measures of goal achievement	9. Various sources of information; methods used	
2. Project purpose	10. Measures of purpose achievement	11. V. sources of information, methods used	7. Purpose-overall objective linkage
3. Results	12. Magnitudes of results; planned dates of completion	13. Various sources of information; methods used	6. Result- project purpose linkage
4. Activities	14. Inputs	15. Project data, other sources of information	5. Activity-result linkage

Table 4.2: Structure of the Logframe [EC, 2004c; AusAID, 2003]

Constructing Project Description (the first column of the Logframe) involves breakdown of the chain of causality in the project design. It summarises what the proposed project intends to achieve and how by clarifying the causal relationships between the different levels of objectives. When the objective hierarchy is read from bottom up, it can be expressed in terms of [EC, 2004c; AusAID, 2004]:

IF the adequate inputs/resources are provided, THEN activities can be undertaken;

IF the activities are undertaken, THEN results can be produced;

IF results are produced, THEN the project purpose will be supported;

IF the project purpose is supported, THEN this should contribute towards the overall objective.

This is also known as *vertical logic*. The logic is tested and refined by the analysis of assumptions in the fourth column of the matrix. The vertical logic (column 1&4) works as follows [EC, 2004c]:

- once the activities have been carried out, and if the assumptions at this level hold true, results will be achieved;
- once these results and the assumptions at this level are fulfilled, the project purpose will be achieved; and
- once the purpose has been achieved and the assumptions at this level are fulfilled, contribution to the achievement of the overall objectives will have been made by the project.

The indicators, which are to be used to measure progress, are listed in the second column, while the third column shows how the data for each of the indicators is to be collected. This is known as the *horizontal logic* of the project. [AusAID, 2003; EC, 2004c]

The Logframe helps to indicate the degree of control managers have over the different levels of the project's objectives. Managers should have significant direct control over inputs, activities and the delivery of results, and should be held appropriately accountable for effectively managing these elements of the project. However, managers can only exert influence over the achievement of the project purpose through the way in which the delivery of results is managed. Project managers generally have no direct influence over the contribution the project makes to the overall objective, and can only be expected to monitor the broader policy and programme environment to help ensure the project continues to be contextually relevant. [EC, 2004c]

The necessary and sufficient conditions within the vertical logic are another way of viewing this issue. These indicate that [EC, 2004c; AusAID, 2004]:

- Achieving the purpose is *necessary but not sufficient* to attain the overall objective. This is because the project is one of a number of projects or initiatives that contribute to the overall objective.
- Producing the project results is *necessary but may not be sufficient* to achieve the project purpose. Other factors beyond the projects control are likely to have influence on achievement of project purpose
- Carrying out project activities should be *necessary and sufficient* to deliver the results (although some risks may remain)

#### 4.2.2. Terminology

As mentioned before various agencies use different terminology in the LFA. Different terms used for three levels of objectives are presented in the table below.

EU	DFID, AusAID	NORAD, DANIDA	SIDA	CIDA
Overall Objective	Goal	Development Objective	Development Objective	Impact
Project purpose	Purpose	Immediate Objective	Project Objective	Outcome
Results	Project Outputs	Project Outputs	Results	Outputs

Table 4.3: Terms used for three levels of objectives by various agencies [Interventions Ltd., 2003]

Although the meaning of these terms is the same, only EU terminology has been used in the report in order to assure the coherence in further reading.

A brief description of the terminology is given below [SIDA, 2004; AusAID, 2003; EC, 2004c; DANIDA 1996, NORAD, 1999]:

##### **Overall objective**

Overall objective refers to the sector or national objectives to which the project is designed to contribute in sustainable way e.g. increased incomes, reduced unemployment etc. The overall objective describes the long-term social and /or economic impact that the project is expected to contribute towards but is not only accountable for. Normally, progress towards the overall objective will depend of a number of related projects beyond the control of the project itself.

##### **Project purpose**

Project purpose is the reason why the project is needed. It states the expected outcomes or direct effects of the project. These are the benefits which beneficiaries derive from the project. These are usually behavioural changes rather than changes in knowledge or attitude. Examples might include improved system of production and services, increased market products, higher efficiency etc. The 'project purpose' is the objective that should have been achieved at the end, or soon after, the project life.

The project should preferably have one purpose. The hypothesis is that the identified set of outputs will deliver the stated purpose. If a second purpose is identified for the project, it will be necessary to provide for a second set of outputs, which will deliver this second purpose. In effect, therefore one has two projects under the garb of a mother project. This can be done as long as the critical relationship between the outputs and purpose is made clear.

### **Results**

Results are the direct outputs of the activities that are implemented within the framework of the project. These are tangible products (goods and services) produced by undertaking a series of tasks or activities. Several activities are often necessary in order to reach one output. Examples might include new process units constructed, staff effectively trained etc. The delivery of project outputs should be under project management's control.

### **Activities**

Activities refer to the specific tasks undertaken to achieve the required results. Several activities may be necessary in order to reach one output. However, the matrix, should not include too much detail on activities otherwise it becomes too lengthy. If detailed activity specification is required (issues of timing, dependency and responsibility) this should be presented separately in an activity schedule and not in the matrix itself. The main activities identified through a Logframe are a summary of what a project must do in order to deliver the project's results.

### **Inputs**

Inputs refer to resources required to undertake the activities. Popularly referred to as 3xM: manpower, money and materials. The inputs in the matrix should only specify a summary of the resources necessary to undertake the activities.

### **Objectively verifiable indicators**

Objectively verifiable indicators (OVIs) refer to the information needed to determine progress towards meeting project objectives. More specifically, OVIs describe the project's objectives in operationally measurable terms (quantity, quality and time – QQT). Specifying OVIs helps to check the feasibility of objectives and helps form the basis of the project's monitoring and evaluation system. A good OVI should be S-M-A-R-T :

- Specific to the objective it is supposed to measure
- Measurable (either quantitatively or qualitatively)
- Available at an acceptable cost
- Relevant to the information needs of managers
- Time-bound – the expected date of the objective fulfilment is known



**Means/source of Verification**

Means/source of Verification (MOVs) should be established for each indicator after the indicators have been developed. MOVs should test whether or not an indicator can be realistically measured at the expense of a reasonable amount of time, money and effort. The MOV should specify: the format in which the information should be made available (e.g. reports, records, research findings, publications), who should provide the information, when or how regularly it should be provided.

**Assumptions**

Assumptions are external factors that refer to conditions which could affect the progress or success of the project, but over which project managers have no direct control. They are the answer to the question: „What external factors may impact on project implementation and the long-term sustainability of benefits, but are outside project management's control?”

Assumptions are usually progressively identified during the analysis of stakeholders, problems, objectives and strategies. The aim of specifying assumptions is to assess the potential risks to the project concept right from the initial stages of project planning, support the monitoring of risks during the implementation of the project and, provide a firm basis for necessary adjustments within the project whenever it should be required.

The importance of each assumption depends on (a) the probability that it will not happen, and (b) the importance to the project if it does not happen. If an assumption is more or less certain to happen and not of great importance to the project success then the manager does not need to worry. If, on the other hand, the chances of the assumption actually happening are low and it is very important to project success the assumption is a 'killer assumption'. This requires the design to be modified. If possible the external factor or assumption should be internalised so that project management can take responsibility for it. If this is not possible, then, the project may need to be redesigned more fundamentally.

**4.2.3. Comparison the LFA with other 'project theories'**

Other tools for expressing a project theory include 'path diagrams', 'program/project templates', 'concept maps', and 'textual descriptions'. Very brief description of these alternatives is presented below followed by a short discussion of each in view of the LFA [Cooksy et al., n.d.]:

- 'Path diagrams' express the cause-effect relationships that explain how a project intervention produces its effects.
- 'Program templates' are matrices in which the first column identifies key activities of effective projects (identified from research and/or project personnel), the second column lists how a specific project plans to incorporate each activity, and the third column summarises data on what actually occurred in the program.

- ‘Concept maps’ display the components that make up a project variable in a map with distances between components and groups of components indicating their similarity
- ‘Textual descriptions’ are written descriptions of how a project is supposed to operate and the relationship of the project activities to the desired effects.

Compared to the options, the LFA is unique in communicating the relationship of project resources and operations to outcomes in a simple picture.

‘Path diagrams’ share the simplicity of the LFA, but usually start with project activities or outputs, rather than with antecedent conditions. Without outlining expected resources and support activities, ‘path diagrams’ are likely to be less useful than logic models when diagnosing why a project does not have the intended effects.

Like the LFA and ‘path diagrams’, ‘project templates’ distil detailed descriptions of the assumptions underlying a project into a format that is easy to follow, however they emphasise project activities instead of the connections between resources, activities, and outcomes.

Similarly, ‘concept maps’ tend to be limited to a single step in the sequence of resources, activities, outputs, and outcomes.

Finally, ‘textual descriptions’ can be more complete than charts, diagrams, or matrices, but written presentations of program theory are not consistent in their content and therefore are not useful as a generally recommended framework.

Summing up the LFA has more potential as an integrative framework than some of the other tools for expressing a project theory.

#### **4.2.4. Criticism behind LFA**

There are a few aspects that have been criticised as conceptual weaknesses or limitations of the LFA. In the following these risks and weaknesses are presented together with their implications for the RUP [Gaspar, 1999; Jackson 1997]:

##### **‘Logic-less frames’**

One improper use of the LFA is that often only a matrix is drawn up, and the matrix is drawn up after the project has already been designed. In this case the LFA is not used to guide the whole project design process. Instead only the format used to summarise the findings of the LFA process is applied to describe a pre-existing design, rather than create a logically solid one. The result is a “filling in the boxes – exercise”.

Skipping the process to get easier to the “product” (matrix) ignores the internal logic and philosophy of the approach and the “product” can only be as good as the analysis and planning process undergone beforehand has been.

The reasons for carrying out such “filling in the boxes – exercises” sometimes might be lack of understanding, (mistaking the matrix for the approach) or the fact that using the LFA is a requirement set out by a funding agency.

In this report LFA has not been used to guide the whole RUP design process since the RUP has been already designed. LFA in this report has been the main evaluation tool to check the logicity of the RUP and whether each component of the project is clear and reasonable. In order to avoid ignoring the philosophy of the approach the question list (based on LFA method and relevant to the issue) has been elaborated to inspire a logical analysis and reflect the hypotheses on which the matrix was built. (See Appendix C)

### **‘Lack-frames’**

One of the LFA’s limitations criticised is that in complex and sometimes even relatively simple project settings the Logframe can be too simple for describing the project design so that important aspects are left out. The LFM in this case is no summary of a project’s key aspects but rather a lack-frame. The matrix might be complemented with additional important information, but by doing this the idea of the matrix as a project summary providing a rather quick overview of the most important aspects of a project does not hold true any more.

GL’s Residue Upgrading Project is a complex one. In order to avoid a ‘lack-frame’ the most important information (necessary to undertake the next level in the project description) has been included in the matrix.

### **‘Lock-frames’**

Another risk with the application of the LFA is the “freezing” of analysis and planning results derived from an initial situation by leaving a LFM, once it has been drawn up, as it is without updating it. The result is a ‘lock-frame’ that limits flexibility. Another difficulty with applying the LFA possibly resulting in lock-frames concerns the work in environments of great uncertainty and change.

### **Limitations with respect to single LFA tools**

Beginning with the problem analysis may produce poor results. First, because some cultures may consider it inappropriate to openly discuss problems or criticise. Second, because the initial focus on problems might limit the vision of potential objectives and third, because beginning with the problem analysis might not be suited to situations where there is a high degree of uncertainty involved or where agreement cannot be reached on the main problem.

### 4.3. Evaluation approach and LFA

A project can be described as a single cause-effect chain of identifiable elements which makes easier to focus the evaluation [DANIDA, 1999]. Logical Framework can be used as reference when evaluating project according to the Five Evaluation Criteria which in turn serve as a basis for considering specific evaluation questions [JICA 2004; EC, 2004c]. Figure below illustrates the link between the Five Evaluation Criteria and the Logframe's objective hierarchy.

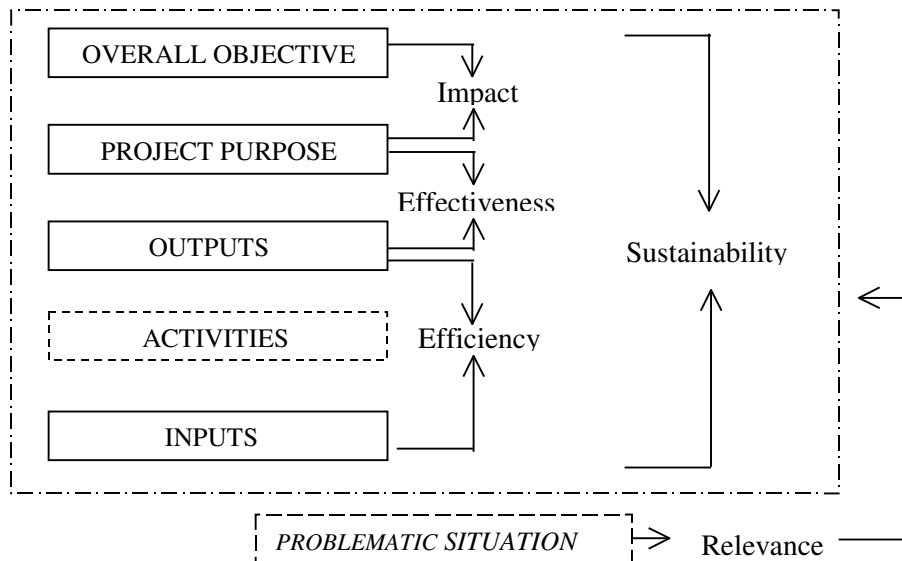

Figure 4.2: Relationship between Five Evaluation Criteria and the Logframe [EC, 2004c]

This figure mainly shows the relationship between the Five Evaluation Criteria and the Logframe. In this report the Logframe is the basic information source in the ex ante evaluation however it is necessary to look at other information as well. For instance when evaluating [JICA, 2004]:

- Relevance, such information as background of project, the needs of the beneficiary, and project strategies, is needed;
- Impact, not only the overall goal described as an expected effect in Logframe, but also unexpected positive and negative influences
- Sustainability various questions have to be raised as is described on the following page

Ex ante evaluation approach do not evaluate performance but rather the validity of a plan based on forecasts and prospects and thus include essentially two aspects [JICA, 2004]:

- Checks whether each component of the project is clear and reasonable. Here, the adequacy of the established indicators and targets and the means of obtaining the indicators are considered.

- Examines whether the structure of a project plan (i.e., the relation between the purpose and the means) is adequately formulated and whether there are forecasts/prospects that the expected objective will be achieved. This questions the logic of the causal relationships between the individual components of a project.

Based on the above grounds the following evaluation questions have been specified:

### **Questions regarding relevance**

*Is the RUP in line with the needs of the target group?*

*Is the project adequate as a strategy to produce an effect with respect to development issues of the oil-refining sector?*

### **Questions regarding efficiency**

*Are sufficient activities planned to produce the output? What are the important assumptions from activities to the output?*

*Do the indicators for the output accurately express their meaning? /What are the means of obtaining the indicators?*

### **Questions regarding effectiveness**

*Will the project purpose be achieved as the effect of the output? What are the important assumptions from the output to the project purpose?*

*Do the indicators for the project purpose accurately express its meaning? /What are the means of obtaining the indicators?*

*Timetable of the RUP*

### **Questions regarding impact**

*Are there prospects that the overall objectives will be produced as an effect of the project? What are the important assumptions from project purpose to overall objectives?*

*Do the indicators for the overall objective accurately express the objective? /What are the means of obtaining the indicators?*

*What are the other effects beyond the overall objectives?*

### **Questions regarding sustainability**

*Is there any possibility that the RUP is inhibited through a lack of consideration for the environment?*

*Are there measures to secure budget after the implementation of the RUP?*

*Is there organisational capacity to implement activities to produce in the long term?/(Is the maintenance of the new units secured?)*

## **4.4. Methodology**

This subchapter provides information how the analyses in the report have been structured and what follows is the presentation of data collection methods used in this study.

### **4.4.1. Structure of the analysis**

The methodology developed in the analysis is based on a two step approach. Step one focus on collecting the necessary information about the project using the LFA. The aim is to present logical summary of the key factors of the proposed project. The following information will be assembled in this process:

- What are the development issues that the project contributes to?
- How effective are the project strategies for solving the development issues, which is the most effective one?
- What are the main components of the project?
- What are the main stakeholders?
- What effects does the project aim to produce?
- How are causal relationships structured between project implementation and effects?
- What are the external factors and risks?
- What are the inputs and how much are the costs, etc.?

Step two uses the end product of the LFA to check whether undertaking of the proposed project is relevant and whether there are prospects that it will be effective, efficient and sustainable. Also the project impact will be measured to the extent what is possible for the evaluation at the planning stage. The aim is to verify the appropriateness of the project by looking at its plan via the Five Evaluation Criteria.

### **4.4.2. Data collection**

This section discusses the methods used for collecting data from the various sources incorporated in this report:

#### **Literature**

*“To determine the questions that are the most significant for a topic, and to gain some precision in formulating these questions, requires much preparation. One way is to review the literature on the topic” [Yin, 1984]*

The literature search involved reviewing readily available materials. These included books, online databases, internal company information, company literature, and other published materials.

This source was used to gain insight into how the oil sector operates and what challenges oil refiners face to meet more stringent environmental goals set by the EU. This source was also an inspiration for the research question as well as on the way the analysis has been structured.

### **Interviews**

*“One way of the most important sources of case study information is the interview”. [Yin, 1984]*

Focused interview has been completed by three representatives from GL and used for collecting data about design of the project being evaluated and supplementing the information not provided in readily available documents. (See Appendix C)

The following guidelines have been used in conducting the interview [Foddy, 1993]:

- *Open questions.* By asking open questions, the respondent is given the opportunity to provide whatever information he or she wishes. It also gives the interviewer a chance to ask follow-up questions, so that he or she can gain a deeper understanding of the respondent's views.
- *Flexibility of structure of the questions.* When the respondent answers one of the later questions earlier in the interview, this has been noted and the question is either not asked, or altered. Also, if new questions arise during the interviews, they are asked when there is time. This flexibility ensured that the respondents did not get frustrated with having to answer the same question multiple times, and that as much information as possible is collected.

## 5. Logical Framework Analysis of the RUP

This chapter presents the logical framework of the RUP, which serves as a basis for further project examination based on the Five Evaluation Criteria. It starts by conducting the analytical process of the Logical Framework Approach together with the description of its main steps. The end product in the form of matrix is presented at the end of this chapter.

### 5.1. Problem analysis

Development projects are usually response to addressing and overcoming identified development problems. One main tool used in problem analysis is the 'problem' tree' where the cause-effect relationships between the identified problems are visualised in the form of a diagram. The causes are the roots of the problem, which in turn symbolises the trunk of the tree and the effects of the problem are the top of the tree. By drawing a 'problem tree' it is possible to find out how the problems are related to each other. The key purpose of this analysis is to try to ensure that 'root causes' are identified and subsequently addressed in the project design. [EC, 2004c; Jackson, 1997; AusAID, 2003; SIDA, 2004]

The figure below presents the cause-effect relationships between GL's problems.

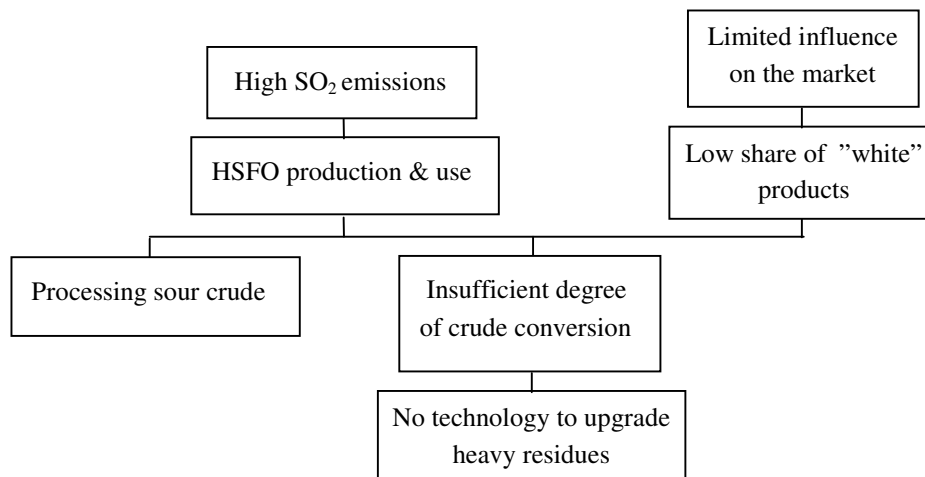

Figure 5.1: GL's problem tree

GL process mainly sour Russian crude, which results in production of HSFO that will not meet EU sulphur content requirements after the transition period during which Polish firms do not need to comply with specific EU Directives. At the same time, adopting EU's Large Combustion Plant Directive could result in significant fuel oil surpluses if conversion is not added since using vacuum residue as refinery fuel component - after satisfying the base oils and bitumen manufacturing requirements - will not be an acceptable solution. In addition demand of the barrel is getting "whiter" meaning that a larger portion of light products and especially of transport fuels is being sought. Processing sour crude without



high degree of conversion results in low share of light products being produced which restricts GL's ability to influence the market. [Zgoda et al.,2005]

A 'problem tree' provides a basis on which to develop a set of relevant and focused project objectives. [EC, 2004c; AusAID, 2003]

## 5.2. Objectives analysis

While problem analysis presents the negative aspects of an existing situation, analysis of objectives describes a future situation that will be achieved by solving the identified problems. [Jackson, 1997; DANIDA, 1996]

During analysis of objectives potential solutions for a given situation are identified. This involves the reformulation/rewording of the negative statements (problems) into positive ones (objectives) drawing up an "objectives tree". In the "objective tree" the objectives are structured in a hierarchical order and the former cause-effect relationships between the key problems are turned into means-end relationships between objectives. The top of the tree is the end that is desired and the lower levels are the means to achieving the end. [EC, 2004c; Jackson, 1997; AusAID, 2003; NORAD, 1999]

The figure below presents the means-end relationships between GL objectives.

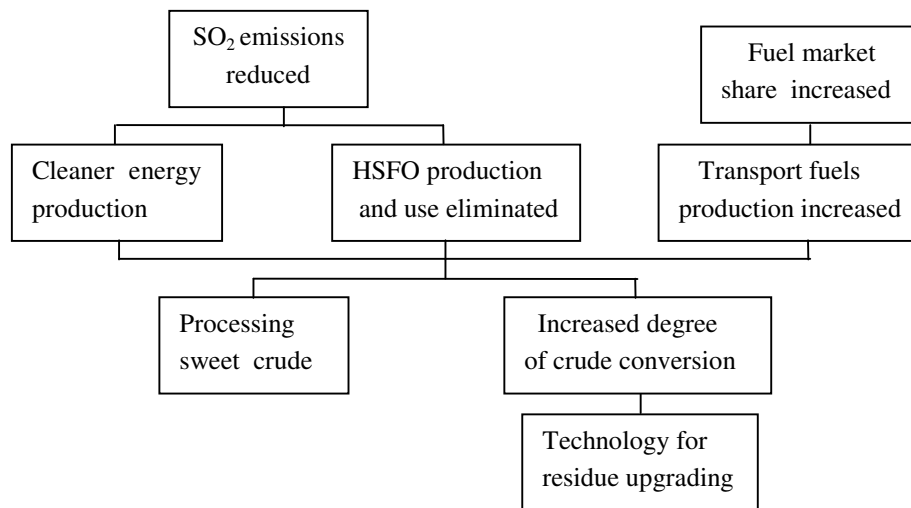

Figure 5.2: GL's objective tree

GL has to eliminate HSFO production and use cleaner fuel for its energy production to reduce SO<sub>2</sub> emissions in order to comply with EU Directives. At the same time the company plans to increase the market share of transport fuels by increasing their production. The two potential solutions are either processing sweet crude or increasing degree of crude conversion by applying bottom of the barrel upgrading technology.

The "objectives' tree" is the starting point for strategy analysis. [EC, 2004c]

### 5.3. Strategy analysis

The 'objective tree' depicts possible strategies that can comprise a solution to the focal problem. Strategy analysis indicates which objectives will and which objectives will not be pursued within the frame of the project. The main objectives become the project purpose and the lower order objectives become the outputs or results and activities. [EC, 2004c; AusAID, 2003]

In the report the strategy analysis examines the feasibility of different options of residue upgrading rather than option of changing the crude slate. The reason behind this is that GL has decided to implement capital intensive project to upgrade the Gdańsk refinery in order to take advantage of well established market trends and access to the relatively cheap Russian oil. This decision results in the necessity to build installations, which can process heavy petroleum processing residuals allowing GL to limit the yields of heavy products and simultaneously increase production of transport fuels.

The following options for residue upgrading has been taken into consideration [GL 2004b]:

*Option 1. Residue (hydro) desulphurisation.* In this process sulphur can be removed from heavy residue stream with the aid of hydrogen. Organic sulphur compounds are converted into hydrocarbons and H<sub>2</sub>S with the aid of hydrogen. Most of desulphurised residue stream is further processed in gasoline and diesel blending blocks. The remaining is LSFO (S content of 1%).

*Option 2. Residue hydrocracking.* This process also uses hydrogen to convert (crack) heavy residue stream to lighter low boiling hydrocarbons. However, higher temperature is used and longer contact time, resulting in significant reduction in feed molecular size. Cracked residue stream is further processed in diesel blending block. The intermediate product from this process is a mix of deasphalted oil and vacuum gas oil (hydrowax), which can be sold as a fluid catalytic cracking feedstock for manufacture of 10 ppm S gasoline without further post-treatment or as low sulphur component for a fuels oil pool.

*Option 3. Residue solvent deasphalting (SDA) followed by gasification (IGCC) and mild hydrocracking (MHC).* This process has been described in detail in Chapter 3 of this report.

In order to match the market requirements and demand regarding petroleum product quality and quantity GL aims at increasing degree of crude conversion. This will include adding new conversion units for processing heavy refinery residuals. As a result the whole range of transport fuels will meet 10ppm S standard. In addition the quantity of these fuels will substantially increase at the expense of undesired HFO production. Means-ends relationship between objectives is displayed in the figure below.

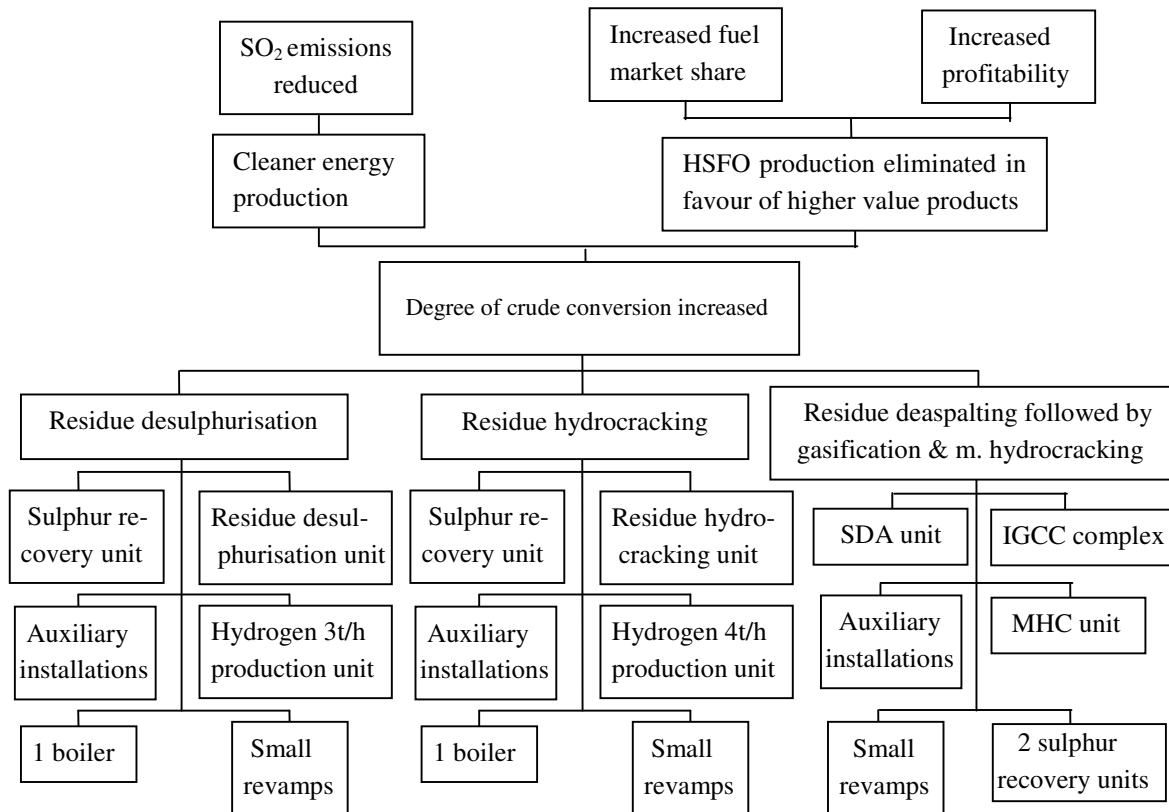

Figure 5.3: GL' objective tree – residue-upgrading options [GL, 2004b]

The strategy analysis has been based upon set of criteria (including among others economic and environmental factors) according to which the best alternative has been selected. In the process of the best option selection GL has taken into consideration the ability of the process to eliminate high sulphur fuel oil production and maximally reduce production of low value low sulphur fuel oil (LSFO). Following market demands regarding transport fuels GL has also considered increase in the production of these products (especially middle distillates) combined with the ability of these processes to reduce S content to 10 ppm in the fuels produced from residue. Selection criteria together with the results have been displayed in the table below.

Selection criteria	Residue desulphurisation	Residue hydrocracking	Residue gasification (SDA, MHC)
Gasoline & diesel 10 ppm S	Yes	Yes	Yes
HFO (S 3% wt) million tonnes/year	0	0	0
LSFO (S 1% wt) million tonnes/year	0.55	0	0
Gasoline million tonnes/year	up to 1.56	up to 1.6	up to 1.69
Diesel million tonnes/year	up to 1.55	up to 1.8	up to 2.45
SO <sub>2</sub> emissions from power generation (mg/Nm <sup>3</sup> )	1700	1700	10
Capital cost, US \$ million	438.5	444	760
Increased margin US \$ million/year	up to 242	up to 255	up to 325

Table 5.1: Comparison of refinery bottoms processing options [GL, 2004b]

As shown in the above table all the processes compared are capable of eliminating HSFO production and permitting a reduction of S content of the whole pool of transport fuels. Option 3 gives the best opportunity in terms of the quantity of annual production of middle distillates. Option 1 is on the third place and the only process manufacturing LSFO.

In order to reduce SO<sub>2</sub> emissions from power generation stringent environmental limits are being imposed on the quality of fuel that refineries can burn, increasing the cost of refinery marginal fuels. In option 1 burning LSFO as the refinery marginal fuel will be a solution while option 2 will blend its intermediate product with other components to produce fuel with permissible S content. Both options offer expensive solution for operating just at the sulphur emission limit. Option 3 gives an opportunity to avoid having to make investments for environmental reason as it will use clean syngas in furnaces and boilers and reduce emissions by more than 99% compared to permissible level.

Apart from the capital cost of each technology, residue deasphalting followed by gasification and mild hydrocracking also offers the best option in terms of profitability.

## **5.4. Stakeholder analysis**

*Stakeholder analysis* is an analysis of the problems, fears, interests, expectations, restrictions and potentials of all that may have an influence on a project or are themselves affected by it. A basic premise behind the analysis is that different groups have different concerns, capacities and interests, and that these need to be understood and recognised in the process of problem identification, objective setting and strategy selection. [EC, 2004c; Jackson, 1997; SIDA, 2004]

Those analysed in detail should be limited to those who “own the problem”. This means those who are perceived to be able to contribute to questions to be answered and are important with regard to decisions to be taken. [Jackson, 1997; SIDA, 2004]

Stakeholders can be divided up into four main groups [SIDA, 2004]:

- Beneficiaries/ Target group
- Implementers
- Decision makers
- Financiers

In this report *stakeholder analysis* has been presented after the analysis of alternatives in order to indicate stakeholders that are most central to the strategy selected and play a significant role in the success or failure of the proposed project.

To help structure *stakeholder analysis* a matrix format have been used to provide summary profile of how different stakeholders may affect the proposed solution. The matrix has

been based on stakeholders' individual characteristics and subsequently the expected implications for a project. The findings have been displayed below.

<i>Stakeholder</i>	<i>Main implication for the RUP</i>	<i>Positive and/or negative impact</i>
Grupa Lotos	To apply new refinery units based on reliable technologies of international concerns	
LESA	Attracting lenders and equity investors, co-ordinating the project	Reducing the risk of GL's operations – the liability towards the financing institutions will be limited to the balance sheet of LESA
Kellog Brown & Root and Shell Global Solutions	License agreements of the core technologies of the RUP Agreement involving support and technical supervision	Provision of advisory services with respect to the management of the RUP during the design, construction, start-up and operation of the RUP units
Lockheed Martin Corporation	Financing license fees for Kellog Brown & Root and Shell Global Solutions technologies by Lockheed Martin	
BOŚ EIB EBRD	Support in terms of capital investments and credit loans	Core of financing of the RUP
STASCO	Long-term purchase agreements with LESA on products from the RUP	Security against repayment of loans to banks

Table 5.2: Stakeholder matrix [Zgoda et al., 2005]

## 5.5. Logical Framework matrix of the RUP

Following an analysis of the problems, the objectives, and the stakeholders a Logical Framework matrix has been prepared. The matrix contains an outline of the logical steps, which are necessary to achieve the objectives, provided that the assumptions are realised. Figure 5.3 has been used to start framing the objective hierarchy in the first column of the matrix. However ongoing checking means-end logic have required further adjustment and refinement of statements. In order to help the reader to recognise more easily what is a purpose, output or activity statement, a convention has been used whereby an overall objective, the project purpose statement is written in the infinitive (“to do something”), the output is described in the future perfect (“something will have been produced”), the activity is described in the present tense as an active verb (“do something”). [AusAID, 2003]

The matrix has been completed according to the general sequence as presented in subchapter 4.2.1. It starts with the project description (top down), then the assumptions (bottom up), followed by the indicators and then source of verification (working across). [AusAID, 2003; EC, 2004c]

The matrix presents the summary of the RUP design. Its vertical and horizontal logic is further analysed in the following chapter. Information contained in the matrix is mainly based on the interview presented in the Appendix C.

<i>Project Description</i>	<i>Objectively Verifiable Indicators</i>	<i>Means of Verification</i>	<i>Assumptions/ External factors</i>
<p><b>Overall Objectives:</b></p> <p>To increase share in the domestic wholesale and retail fuel market</p> <p>To increase profitability</p> <p>To improve environmental performance of the refinery / To reduce negative impact on the environment</p>	<p>The overall share of the Polish fuel market increased from 21% to 30%, and of the retail fuel market from 6.0% to 12% in 2010</p> <p>Refining margin increased from 150 – 355USD mln/p.a.</p> <p>Secondary SO<sub>x</sub> emissions reduced by approx. 45,000 tons/p.a. in 2009 (in the country and North-West Europe) due to eliminated HSFO production</p> <p>The refinery SO<sub>x</sub> emissions reduced from 5497 to 3114t ons/p.a.) in mid 2009</p> <p>IPPC Directive recommends IGCC as BAT in energy production - less CO<sub>2</sub> emissions per unit of electric power produced than in conventional power stations</p>	<p>Główny Urząd Statystyczny (GUS) – Central Statistical Office of Poland</p> <p>GL's 'Financial Statements' quarterly report</p> <p>Data from automatic measurement stations in GL refinery</p> <p>IPPC Reference Document on BATs for Mineral Oil and Gas Refineries</p>	
<p><b>Project purpose:</b></p> <p>To increase the scale and degree of crude conversion with the world-scale units</p>	<p>HSFO production reduced from 0,8 Mt/p.a to zero in mid 2009</p> <p>Hydrowax production 0,8Mt/p.a.</p> <p>10 ppm S transport fuels production increase in mid 2009: Gasoline from 1,15 to 1,69 Mt/p.a Diesel from 1,43 to 2,45 Mt/p.a. JET A-1 from 0,54 to 0,75 Mt/p.a.</p> <p>Environmentally generated power and steam for refinery use (balance to 44 MWe and 72MWh)</p> <p>Cost-effective hydrogen production 216t/d</p>	<p>LOTOS Lab QC (quality control) tests</p> <p>GL's 'Product balance' reports issued quarterly</p>	<p>Oil prices of USD 20-25 bbl</p> <p>Successful execut. of PROSTA</p>

<p><b>Outputs/Results:</b> Heavy Residues Conversion Complex will have been ready to operate in 2009</p>	<p>In 2009 IGCC/ SDA/MHC units constructed with the following processing capacity: SDA – 330 ton/hour VR/AR MHC – 260 t/h DAO IGCC –68 t/h asphaltene</p> <p>All the necessary adjustments conducted allowing the new plant for effective integration with the existing refinery (see activities)</p>	<p>Operating permit issued</p>	<p>Feedstock acquisition assured</p> <p>The new units meet the operating parameters</p>
<p><b>Activities</b> To construct IGCC, SDA and MHC units</p> <p>To modernise power supply section and waste water treatment plant</p> <p>To construct imported feedstock desalter</p> <p>To design and construct interconnecting piping, pipe racks and pipe trenches in the refinery</p> <p>To construct new buildings (substation, control room)</p>	<p><b>Inputs</b></p> <p><u>Cost</u> <i>Capital expenditure:</i> SDA - 55 USD million MHC - 165 USD million IGCC - 365 USD million <i>Associated upgrades:</i> 89 USD million <i>Offsite:</i> - 69 USD million <i>License fees</i> - 15 USD million <i>Operating/maintenance:</i> 55 USD million per annum</p> <p><u>Time</u> 1.2006 – tenders for technical designs and construction work, execution of the base projects 2. End of 2006 - financial closure 3. 2007-2009 - execution of the project construction contracts 3. May 2009 - start-up and commencement of operations</p>	<p>Management reports on physical and financial progress of the RUP</p>	<p>No delays in project execution</p>

Precondition:  
Financing Assured

## **6. Analysis of the RUP via the Five Evaluation Criteria**

The focus of this chapter is to assess the validity of the RUP plan by answering basic questions about the project according to the Five Evaluation Criteria. Each criterion comprises several questions as introduced in subchapter 4.3.

### **6.1. Relevance**

When evaluating the relevance of the RUP the extent to which its stated objectives correctly address the identified problems or real needs is examined. The evaluation also relates to checking whether the project strategy is adequate to produce an effect with respect to development issues of the oil-refining sector.

#### **6.1.1. Needs**

*Is the project in line with the needs of the target group?*

The main aims of the RUP are to solve the problem of heavy residues and lower the refinery SO<sub>2</sub> emissions. The heart of the project is the conversion of heavy, environmentally damaging residues, the market value of which is low, into profitable products, technical gases and energy.

Power generated in the refinery using high-sulphur fuels will be replaced by power co-generated with desulphurised synthesis gas and will help the refinery to comply with the EU standards regarding emission levels.

The requirement to reduce the sulphur content in the whole pool of engine fuels to 10 ppm means that the refinery will need more hydrogen available for hydroprocessing. The gasification trains will be able to produce hydrogen required for both the new and the existing hydrocracker. The new units will supplement GL's existing technology especially the distillate hydrocracking and will mean that the share of highly refined products "white products" will increase while HFO will no longer be manufactured.

By implementing the RUP, the key strategic drivers of the refinery will be satisfied. HFO production and exports will be eliminated and environmental as well as financial performance of the refinery will be improved.

Integrated with a deasphalting unit and a hydrocracker, the Shell gasifier with power block seems to be the comprehensive solution for the Gdańsk refinery in addressing GL's needs.

#### **6.1.2. Strategy**

*Is the project adequate as a strategy to produce an effect with respect to development issues of the oil-refining sector?*



In order to meet development issues in the oil refining sector regarding product demand and quality requirements GL has adopted strategy which choice has been dominated by raw material prices and availability. This implies processing Urals and in turn heavy investment in the refinery upgrade.

The choice of the technology has been based on several factors, which indicated that the IGCC combined with SDA/ROSE and MHC is the best solution in both economic and environmental terms when compared to other residue upgrading options taken into consideration. More detailed information on strategy selection can be found in subchapter 5.2.

Thanks to the planned investments in refining technologies it will be possible to completely eliminate production of HFO (the consumption and prices of which will probably be characterised by a downward trend) in favour of products typified by higher profitability such as diesel oil, gasoline, jet fuel and hydrowax - all meeting sulphur specifications. Significant increase in transport fuels production is justified by market analyses that indicate that these products are favourably placed in long-term trends on the domestic as well as EU market. Forecasts concerning market tendencies therefore confirm the rationale for significant changes in the production mix.

## **6.2. Efficiency**

Measuring the efficiency of the RUP is based primarily on assessing the appropriateness of the causal relationship (vertical logic) between activities and output at the same taking into account important assumptions that may influence this relationship. Horizontal logic of the output is also verified in order to see whether the progress or failure of the project can easily be checked. Evaluation of the efficiency also examines the general timing plan of the project, which can be used as a base for monitoring the progress of the project. The information could be find in the management reports on physical and financial progress of the RUP.

### **6.2.1. Timing of the RUP plan**

Integrated base project, tenders for technical designs and construction work agreements with contractors are to be ready at the beginning of 2006. However, a precondition for starting the project is to assure financing.

GL has already begun negotiations with entities, which are to provide the financing. These include EIB, BOŚ, and EBRD. Their engagement in pro-environmental investments brings additional benefits that compensate for longer procedures. The above entities will constitute a core of financing of the RUP on the basis of which the strategy towards commercial banks will be formulated. [Zgoda et al., 2005]

The start of execution of core technological projects is planned for the first quarter of 2006 while execution of the project construction contracts after financial closure that is expected

to be finalised by the end of 2006. Mechanical as well as technological start-up are envisaged in mid 2009. [Zgoda et al., 2005]

### **6.2.2. Vertical logic from activities to output**

*Are sufficient activities planned to produce the output? What are the important assumptions from activities to the output?*

The main activities planned to produce the output seem to be sufficient as they take into account all the necessary adjustments required for the new units to effectively operate with the existing refinery. These include [GL, 2004/2005]:

- Modernisation of the power supply section. Integration of the power plant with the refinery will require among others the development of the power supply infrastructure (energy distributors, transformers) connected with the new units.
- Modernisation of the existing wastewater treatment plant will include the development of the new biological line since the realisation of the RUP will result in new sources of the wastewater.
- Construction of the control rooms for the new units.
- Construction of the interconnecting piping among the new and existing units
- Construction of the desalter since additional feedstock for deasphalting unit will be imported by sea and the excess of salt will need to be removed prior to further processing.

Each stage of the project's execution will be subject to a strict budget control, and work on the project will be commissioned to contractors experienced in the execution of such projects. However, given the scope and duration of the RUP, there may occur delays in its execution, which would have an adverse effect on GL performance. In order to further reduce this risk, turnkey contracts providing for specific delivery dates and prices, as well as the right to claim compensation, will be concluded. [Zgoda et al., 2005]

### **6.2.3. Horizontal logic of the output**

*Do the indicators for the output accurately express their meaning? /What are the means of obtaining the indicators?*

The indicator for the output accurately expresses its meaning because it reflects essential aspects of the output in precise terms. It indicates core installations of the Heavy Residues Conversion Complex, together with their processing capacity as well as all the necessary adjustments required for the new plant effective operation.

In Poland operating facility may commence after the operating permit is obtained [Durski et al., 2005]. Thus the indicator draws upon data that can be available from GL's documents.

## 6.3. Effectiveness

Measuring the effectiveness of the RUP is based on assessing the appropriateness of the causal relationship (vertical logic) between the output and the project purpose at the same taking into account important assumptions that may influence this relationship. Horizontal logic of the project purpose is also verified in order to see whether the progress or failure of the project can easily be checked.

### 6.3.1. Vertical logic from the output to the project purpose

*Will the project purpose be achieved as the effect of the output? What are the important assumptions from output to the project purpose?*

When the Heavy Residues Conversion Complex goes online meeting the operating parameters, the project purpose will be achieved.

The complex comprises of three mutually complementing technologies, which when used in combination allow for the extracting of the maximum value from each barrel of oil processed/ maximising conversion capacity.

Connecting the refinery with gasification section will allow to extract the maximum value from the heaviest fractions of residues by converting them into syngas – the clean fuel for power generation and cost effective source for hydrogen production. The addition of the SDA/ROSE will provides minimum cost feedstock (thickened and polluted residues/asphaltene) for a gasifier and allow of the maximum amount of semi-finished product from heavy crude processing residue, from which it will be still possible to produce valuable light oil products. MHC unit will be necessary to process intermediate products obtained in the ROSE unit to high quality fuels meeting EU standards.

In order to complement to indigenous feed to the residue upgrading units GL will need to import of around 1.5 Mt p.a. of atmospheric residue. Atmospheric residue is an intermediate product in the refining industry. In contrast to gasoline and diesel fuels it is not normally produced specifically to meet a market requirement, but as a by-product which can be sold for further processing. Therefore in order to secure appropriate effectiveness of residue conversion units GL consider a term purchase agreement for some of the volume for a period necessary to develop the capacity necessary to produce this type of feedstock by the company itself.

### 6.3.2. Horizontal logic of the project purpose

*Do the indicators for the project purpose accurately express its meaning? /What are the means of obtaining the indicators?*

The project purpose is to maximise GL refinery conversion capacity with the world-scale technologies. These technologies enable the production of light cleaner fuels from a heavy

sulphur rich refinery stream, while in the meantime producing ultra-clean energy. Objectively verifiable indicators for the project purpose accurately express its meaning as they explain in precise terms what increased conversion capacity (when applying these technologies) means for GL. They indicate what kind of products in terms of quality and the quantity will be produced as well as their expected date of the production start-up.

Means of verification for the indicators should be available in the format of GL products' balance reports that are to be issued quarterly indicating the amount of products produced. GL product quality is always checked by LOTOS Lab (see Appendix A) and the relevant information should be found in LOTOS Lab test's reports.

## **6.4. Impact**

The impact of the RUP assess the appropriateness of the causal relationship (vertical logic) between the project purpose and the overall goal taking into account important assumptions that may influence this relationship and verifies the horizontal logic of the project purpose. In addition it indicates other effects both positive and negative beyond the overall objective.

### **6.4.1. Vertical logic from the project purpose to the overall objectives**

*Are there prospects that the overall objectives will be produced as an effect of the project?  
What are the important assumptions from project purpose to overall objectives?*

GL estimates that the implementation of the RUP will substantially increase the company profitability. Considering the fact that the investment will make it possible to change the product structure from low-price products to high quality fuels, prices of which are several times higher, margins will certainly increase. However, the size of the margins will also depend on prices of oil as well as refining margins realised at that time. The Management Board of GL estimates that, following the completion of the RUP, the refinery's margin including variable costs will increase by USD 205 million (assuming oil prices of USD 20-25 per barrel).

Increasing the scale and conversion capacity means that the share and the amount of transport fuels will increase significantly which gives GL the opportunity to better influence the market. However increasing the market share will largely depend on the distribution network. The ability to improve the competitive position of GL on the retail sales market (in particular in relation to the PKN Orlen Group) and increase its share of that market to 12% by 2010 will depend on the successful execution of PROSTA. Due to the strong competition on the retail market, there can be no assurance that this objective will be achieved.

Thanks to the implementation of the RUP the environmental performance of the refinery will be substantially improved. The project is going to permit the reduction of emissions, mainly of sulphur dioxide, into the air, at both local and global scale. Substituting a

synthetic gas fired energy unit for the existing electric heating facility fired using sulphur-rich fuel oil will lower emissions of SO<sub>2</sub> from refinery site while discontinuing production and consumption of HFO will reduce secondary SO<sub>2</sub> emissions. In addition more effective generation of heat and electricity than in conventional power stations will allow for less CO<sub>2</sub> emissions per unit of electric power produced.

#### **6.4.2. Horizontal logic of the overall objective**

*Do the indicators for the overall objective accurately express the objective?/ What are the means of obtaining the indicators?*

There are several objectives that the project is expected to contribute towards as explained in the previous subchapter. All the indicators for these goals are measurable and time-bound and the means of obtaining them are easily available.

Data regarding the share in Polish fuel market can be obtained from GUS in Poland where information is disseminated through direct customer service, and telephone and electronic means [GUS, 2005]. The level of refining margins can be checked in GL's Financial Statements' quarterly report available from the internet, while data on air pollutant emission levels can be obtained from a network of automatic measurement stations in GL.

#### **6.4.3. What are the other effects beyond the overall objectives?**

The other effects beyond the overall objective include the following [Zgoda et al., 2005]:

- Securing and/or expanding employment and business opportunities in the Gdańsk region for the period of 2-3 years due to civil engineering works during implementation of the RUP.
- Threefold increase in CO<sub>2</sub> emissions. Producing sulphur free fuels produces additional CO<sub>2</sub> emissions from refineries. As the effect of the implementation of the RUP CO<sub>2</sub> emissions will increase from approx.1000 to 2800 t CO<sub>2</sub>/year.

### **6.5. Sustainability**

Evaluation of sustainability of the RUP involves examining the continually of its effect. This involves looking at organisational and financial aspects, technology and the environment.

#### **6.5.1. Environment**

*Is there any possibility that a project is inhibited through a lack of consideration for the environment?*

The possibility that the project is inhibited through a lack of consideration for the environment is rather poor. Although CO<sub>2</sub> emissions will increase significantly as the

effect of the RUP this will not hold back the project. The IGCC installations have been recognised as the most effective in generation of heat and electricity than in conventional power stations (less CO<sub>2</sub> is emitted per unit of electric power produced). They are subject to IPPC Directive, which recommends IGCC as the Best Available Technique in energy production. Also the EU's Green Paper on the promotion of renewable sources of energy recommends IGCC installations. Moreover execution of the RUP will bring very significant regional and global environmental benefits in terms of significant reduction of SO<sub>2</sub> emissions.

### **6.5.2. Financial aspects**

*Are there measures to secure budget after the implementation of the project?*

Possession of secured stable revenues from the project is based on the long-term contracts regarding products from the RUP installations. A long-term contract for the delivery of diesel fuel and hydrowax have already been signed by LESA and STASCO. It ensures that STASCO will be purchasing (based on the price formula described in the contract linked to market quotations) a significant portion of these products for a period of 12 years from the moment of RUP units becoming operational. Full entry into force of this contract is conditional on financial closure of the RUP and initiation of operating activity as part of this project within 48 months of financial closure. [Zgoda et al., 2005]

Moreover, the location of GL in Gdańsk creates unique export opportunities for the increased product mass resulting from this investment project.

### **6.5.3. Organisational and/or technological aspects**

*Is there organisational capacity to implement activities to produce in the long term?/(Is the maintenance of the new units secured?)*

The organisational capacity to implement activities to produce in the long term is secured for the following reasons [Zgoda et al., 2005]:

In connection with the RUP, GL has concluded three licence agreements (two with Shell Global Solutions and one with MW Kellogg Limited), pursuant to which GL is to be issued licences for use of the IGCC, MHC and ROSE and technologies. Under the above agreements, the licensor undertakes to disclose to GL or LESA the basic service package information, technical or otherwise held by the licensor, which may be useful or necessary for the preparation of a detailed technical design and construction of the unit under the issued licence.

Another agreements signed with the above licensors apply to provision of advisory with respect to the management of the RUP during the design, construction, start-up and operation of the RUP units.



## 7. Conclusion

In aiming for cleaner environment, the EU through a series of directives pressures to reduce the sulphur content of the refinery products including HFO as well as petrol and diesel fuels.

Sulphur limitations in HFO aim to reduce SO<sub>2</sub> emissions when HFO is burnt while reducing the sulphur content in petrol and diesel fuels is a pre-requisite for the development new engine technology the aim of which is reduction of CO<sub>2</sub> from passenger cars.

Reducing the sulphur content of the refinery products results in larger amounts of heavy petroleum processing residuals with higher sulphur content.

The main refinery products consisting largely of the residue remaining from the distillation of crudes include bitumens used mainly for paving roads, base oils (lubricating greases) as well as HFO primarily used in industrial boilers and other direct source heating applications or as a principal fuel in marine applications in large diesel engines.

Usually major amounts of heavy petroleum processing residuals used to be sold as HFO for use in power generation or in ships as a bunker fuel. However, in order to meet sulphur limits refineries have to add increasing quantities of good quality products to sell them as commercial fuel for ships and utilities the market

Decline in demand for fuel oil, together with an increase in the need for transportation fuels, is motivating refiners to look for new fuel oil outlets and flexible refinery schemes that can improve production of lighter fuels. Processing sweet crudes allows the product to meet requirements for the lower sulphur fuels easier than processing sour crudes. However, the worldwide distribution of lower sulphur crude is not even and the largest reserves of sweet oil are beyond its peak pushing up their price. Discount in the price of Ural to Brent with the same prices of final products creates favourable environment for launching investments for processing sour crudes.

Grupa LOTOS, which is Poland's second leading producer and distributor of oil and petroleum products, plans to implement environmentally friendly technology based on Shell gasification process in order to meet both legislative and business targets. By using this process GL will be able to convert a wide range of low-value, heavy residues and asphaltenes into desulphurised syngas for combined-cycle power generation. When integrated with other upgrading technologies namely solvent deasphalting and mild hydrocracking the important synergies may be realised allowing the maximum value of from each barrel of oil produced to be extracted. Solvent deasphalting will upgrade heavy bottoms streams to deasphalated oil that will be further processed in mild hydrocracker to produce transportation fuels. The by-product of deasphalting (an asphaltene stream) for



which it is often difficult to find beneficial use is a low cost feedstock for gasification plant.

This report has been completed in order to investigate the likely success of GL's residue-upgrading project via analysing it via the Five Evaluation Criteria (Relevance, Efficiency, Effectiveness, Impact and Sustainability). These criteria have been evaluated using Logical Framework Approach as its main evaluation tool.

The analysis of Relevance has revealed that implementation of the RUP is relevant in addressing GL's needs. The company will be able to comply with the EU standards regarding SO<sub>2</sub> emission levels and maximises the economic effects from refining processes. Implementation of this project should improve the financial results of GL thanks to exploiting the effects of scale and increasing the share of products with higher margins, for which demand is predicted to increase both in Western Europe and in Poland. This investment is also relevant in terms of requirements to meet EU quality standards for oil products.

Because the realised worth of the evaluated project has had not a chance to be realised yet, measuring Efficiency, Effectiveness and Impact has mainly involved checking whether each component of the project is clear and reasonable and whether the logicity of the causal relationship between the individual components of a project is appropriate. The analysis has revealed as follows:

- Once financing is provided, the new units can be constructed and all the necessary adjustments allowing them for effective integration with the existing refinery can be carried out;
- Once the new units and all the necessary adjustments allowing the new plant for effective integration with the existing refinery are carried out, and if there are no delays in project execution, Heavy Residues Conversion Complex will be ready to operate in 2009;
- Once Heavy Residues Conversion Complex is ready to operate in 2009, and the new units meet the required operating parameters and supplies of raw materials guaranteeing its execution are ensured, the scale and degree of crude conversion with the world-scale units will increase
- Once the scale and degree of crude conversion is increased, the project will contribute to:
  - improved environmental performance of the refinery,
  - 2.3 times increased refinery margins (if the price of oil do not drop below \$ 20 bbl)

- increased share in the domestic wholesale (from 21 to 30%), and retail (from 6 to 12%) fuel market – the latter will largely depend on successful execution of PROSTA

The management can measure whether project's outputs, purpose and overall objective have been achieved by looking at quantitative and qualitative indicators. The information required to assess progress against indicators can be easily grasped from readily available reports. This could help the project's management to respond to any changes throughout the lifecycle of the RUP as the circumstances change.

The success of the RUP is dependent on the ability to raise financial resources, implement the project according to its plan, ensure supplies of raw materials guaranteeing its execution and securing technological risks related to operation of the new units as well as the expected rate of return connected with implementing this project.

The RUP's management has undertaken or plans to undertake the necessary measures (where possible) in order to secure the project's success. These include turnkey contracts providing for specific delivery dates, term purchase agreements for raw materials as well as agreements with the licensors regarding management of the RUP throughout its lifecycle.

In order to assure the expected rate of return, GL have secured stable revenues from the RUP based on the long-term contracts regarding products from new installations as revealed when measuring Sustainability.

Implementing environmentally friendly technology has several benefits among which the most important one is that the project will not be inhibited through a lack of consideration for the environment. Moreover it will help to persuade investors to steer their money to the company on the basis of its environmental performance.

It should be noted that the credibility of the above finding is very much limited to the quality of the analysis and planning process of the RUP prepared by GL. On the basis of the already existing design the structure of a project plan has been examined and thus evaluation has been limited to checking whether each component of the project has been adequately formulated and whether the risks that may influence success of the project have been addressed in the project design.

Summing up, on the basis of the above GL's Residue Upgrading Project is likely to be successful. However, the installations of the RUP are designed to run most effectively on Ural crudes, which implies that diversification of direction of crude oil supply to GL should be mostly limited to Russia. When Russian supply is disrupted, processing lighter and sweeter crude from the Caspian Sea region that could be supplied to GL would be technically and economically less attractive.



## 8. References

### A

Action & Research Open Web (AROW), 2004a: *Formative Evaluation* (Online) Available from: <http://www2.fhs.usyd.edu.au/arow/o/m06/formative.htm> (Accessed: November 30, 2005)

AROW, 2004b: *Summative Evaluation* (Online) Available from: <http://www2.fhs.usyd.edu.au/arow/o/m06/summative.htm> (Accessed: November 30, 2005)

Australian Agency for International Development (AusAID), 2003: *AusGUIDELines: The Logical Framework Approach* (Online) Available from: <http://www.ausaid.gov.au/ausguide/ausguidelines/ausguidelines-1.pdf> (Accessed: December 1, 2005)

### B

Boston Consulting Group (BCG), 2005: *Create a Winning Strategy for Refining* (Online) Available from: [http://www.bcg.com/publications/files/Creating\\_Winning\\_Strategy\\_Refining\\_Jun\\_05.pdf](http://www.bcg.com/publications/files/Creating_Winning_Strategy_Refining_Jun_05.pdf) (Accessed: September 22, 2005)

Bank Ochrony Środowiska (BOŚ), 2003: *Ogólne informacje o Banku Ochrony Środowiska (General information about Environmental Protection Bank)* (Online) Available from: <http://www.bosbank.pl/i.php?i=14> (Accessed: November 29, 2005)

BRE Bank, 2005: *Raport Analityczny Grupy Lotos (Analytical Report of Grupa Lotos)* (Online) Available from: <http://www.biznespolska.pl/files/reports/Lotos%20080820051.pdf> (Accessed: November 29, 2005)

Bunker World (BW), 2005: *Europe signals new dawn for marine fuelling* (Online) Available from: [http://www.bunkerworld.com/news/apr2005/news\\_13042005\\_10.html](http://www.bunkerworld.com/news/apr2005/news_13042005_10.html) or: [http://64.233.183.104/search?q=cache:7chwLWEaXLkJ:www.bunkerworld.com/news/apr2005/news\\_13042005\\_10.html+EU+bunker+fuel+and+inland+fuel+oil+demand+&hl=pl](http://64.233.183.104/search?q=cache:7chwLWEaXLkJ:www.bunkerworld.com/news/apr2005/news_13042005_10.html+EU+bunker+fuel+and+inland+fuel+oil+demand+&hl=pl) (Accessed: October 5, 2005)

### C

Cooksy, L., P., Gill, and A., Kelly, n.d.: *The Program Logic Model as an Integrative Framework for a Multimethod Evaluation*, Florida State University (Online) Available from: <http://www.hsrh.houston.med.va.gov/AdamKelly/Logic.html> (Accessed: December 2, 2005)

## **D**

Danish International Development Agency (DANIDA), 1996: *Logical Framework Approach: A Flexible Tool for Participatory Development* (Online) Available from: [http://www.um.dk/NR/rdonlyres/A5C92A15-6E14-4F06-80B1-96971D31CD04/0/Logical\\_Framework\\_Approach.pdf](http://www.um.dk/NR/rdonlyres/A5C92A15-6E14-4F06-80B1-96971D31CD04/0/Logical_Framework_Approach.pdf) (Accessed: December 1, 2005)

DANIDA, 1999: *Evaluation Guidelines* (Online) Available from: [http://www.um.dk/NR/rdonlyres/4C9ECE88-D0DA-4999-9893-371CB351C04F/0/Evaluation\\_Guidelines\\_1999\\_revised.pdf](http://www.um.dk/NR/rdonlyres/4C9ECE88-D0DA-4999-9893-371CB351C04F/0/Evaluation_Guidelines_1999_revised.pdf) (Accessed: November 30, 2005)

Dursk, M., K. Siedlik, A. Błach, M. Zieniewski, 2005: *Poland - CMS Electricity Sector* (Online) Available from: <http://www.law-now.com/media/pdfs/en/secured/electricitypoland.pdf> (Accessed: December 15, 2005)

## **E**

Erisman, J., W., 2004: *Acid Deposition and Energy Use*, Encyclopedia of Energy, Volume1, (Online) Available from: <http://www1.elsevier.com/homepage/sai/encycofenergy/acidepo.pdf> (Accessed: September 28, 2005)

Eurostat, 2003: *Statistical aspects of the oil economy in 2002* (Online) Available from: [http://www.eds-destatis.de/en/downloads/sif/nq\\_03\\_15.pdf](http://www.eds-destatis.de/en/downloads/sif/nq_03_15.pdf) (Accessed: October 4, 2005)

Eurostat, 2005a: *News release: A statistical view of environmental issues* (Online) [http://epp.eurostat.cec.eu.int/pls/portal/docs/PAGE/PGP\\_PRD\\_CAT\\_PREREL/PGE\\_CAT\\_PREREL\\_YEAR\\_2005/PGE\\_CAT\\_PREREL\\_YEAR\\_2005\\_MONTH\\_05/8-30052005-EN-BP.PDF](http://epp.eurostat.cec.eu.int/pls/portal/docs/PAGE/PGP_PRD_CAT_PREREL/PGE_CAT_PREREL_YEAR_2005/PGE_CAT_PREREL_YEAR_2005_MONTH_05/8-30052005-EN-BP.PDF) (Accessed: September 27, 2005)

Eurostat, 2005b: *Energy, transport and environment indicators 1992-2002* (Online) Available from: [http://epp.eurostat.cec.eu.int/cache/ITY\\_OFFPUB/KS-DK-05-001/EN/KS-DK-05-001-EN.PDF](http://epp.eurostat.cec.eu.int/cache/ITY_OFFPUB/KS-DK-05-001/EN/KS-DK-05-001-EN.PDF) (Accessed: October 4, 2005)

European Bank for Reconstruction and Development (EBRD), 2005: *About the EBRD* (Online) Available from: <http://www.ebrd.com/about/index.htm> (Accessed: October 28, 2005)

European Commission (EC), 2000: *Towards a European strategy for the security of energy supply*, Green Paper (Online) Available from: [http://europa.eu.int/eur-lex/en/com/gpr/2000/act769en01/com2000\\_0769en01-01.pdf](http://europa.eu.int/eur-lex/en/com/gpr/2000/act769en01/com2000_0769en01-01.pdf) (Accessed: September 27, 2005)

EC, 2003a: *European energy and transport trends to 2030* (Online) Available from: [http://europa.eu.int/comm/dgs/energy\\_transport/figures/trends\\_2030/5\\_chap4\\_en.pdf](http://europa.eu.int/comm/dgs/energy_transport/figures/trends_2030/5_chap4_en.pdf) (Accessed: September 27, 2005)

EC, 2003b: *Advice on Marine Fuel – Potential price premium for 0.5% S marine fuel; Particular issues facing fuel producers in different parts of the EU; and Commentary on marine fuels market*, BeicipFranlab Draft Final Report (Online) Available from: [http://europa.eu.int/comm/environment/air/pdf/beicipfranlab\\_report.pdf](http://europa.eu.int/comm/environment/air/pdf/beicipfranlab_report.pdf) (Accessed: October 6, 2005)

EC, 2003c: *Sulphur content of certain liquid fuels* (Online) Available from: <http://europa.eu.int/scadplus/leg/en/lvb/l21050.htm> (Accessed: September 29, 2005)

EC, 2003d: *Kyoto Protocol on climate change* (Online) Available from: <http://europa.eu.int/scadplus/leg/en/lvb/l28060.htm> (Accessed: October 3, 2005)

EC, 2003e: *Priority Axes and TEN-E Projects* (Online) Available from: [http://europa.eu.int/comm/ten/energy/revision\\_2003/consultation/priority\\_axes\\_and\\_projects\\_en.pdf](http://europa.eu.int/comm/ten/energy/revision_2003/consultation/priority_axes_and_projects_en.pdf) (Accessed: October 6, 2005)

EC, 2004a: *Energy & Transport - Report 2000-2004* (Online) Available from: [http://europa.eu.int/comm/dgs/energy\\_transport/doc/dg\\_tren\\_bilan\\_2000\\_2004\\_en.pdf](http://europa.eu.int/comm/dgs/energy_transport/doc/dg_tren_bilan_2000_2004_en.pdf) (Accessed: September 27, 2005)

EC, 2004b: *Odessa-Brody Oil transportation Pipeline*, Project Dossier - Interstate Oil and Gas Transport to Europe (Online) Available from: [http://www.inogate.org/html/opportunities/PD\\_OBP\\_Oil\\_Pipeline.pdf](http://www.inogate.org/html/opportunities/PD_OBP_Oil_Pipeline.pdf) (Accessed: October 11, 2005)

EC, 2004c: *Project Cycle Management Guidelines*, EuropeAid Cooperation Office (Online) [http://europa.eu.int/comm/europeaid/qsm/documents/pcm\\_manual\\_2004\\_en.pdf](http://europa.eu.int/comm/europeaid/qsm/documents/pcm_manual_2004_en.pdf) (Accessed: November, 30 2005)

EC, 2005a: *Overviews of the European Union Activities: Energy* (Online) Available from: [http://europa.eu.int/pol/ener/overview\\_en.htm](http://europa.eu.int/pol/ener/overview_en.htm) (Accessed: October 5, 2005)

EC, 2005b: *Winning the Battle Against Global Climate Change* (Online) Available from: <http://europa.eu.int/rapid/pressReleasesAction.do?reference=MEMO/05/42&format=HTML&aged=1&language=EN&guiLanguage=en> (Accessed: September 29, 2005)

European Conference of Ministers of Transport (ECMT), 2000: *Fuel Sulphur Limits* (Online) Available from: [http://www.walshcarlines.com/doc/env\(00\)2erev2.doc](http://www.walshcarlines.com/doc/env(00)2erev2.doc) (Accessed: October 3, 2005)

European Environment Agency (EEA), 2002: *Environmental Signals 2000: Air pollution* (Online) Available from: <http://reports.eea.eu.int/signals-2000/en/page011.html> (Accessed: September 29, 2005)

EEA, 2004: *European Environment Agency update on selected issues* (Online) Available from: <http://reports.eea.eu.int/signals-2004/en/ENSignals2004web.pdf> (Accessed: September 29, 2005)

Energy Institute (EI), 2005: *IP Week retrospective: Petroleum Review* (Online) Available from: <http://www.energyinst.org.uk/content/files/ipweek2005.pdf> (Accessed: October 5, 2005)

Energy Information Administration (EIA), 2004a: *Pricing Differences Among Various Types of Crude Oil* (Online) Available from: [http://tonto.eia.doe.gov/ask/crude\\_types1.html](http://tonto.eia.doe.gov/ask/crude_types1.html) (Accessed: October 6, 2005)

EIA, 2004b: *Non-OPEC Fact Sheet* (Online) Available from: [http://www.eia.doe.gov/emeu/cabs/topworldtables1\\_2.html](http://www.eia.doe.gov/emeu/cabs/topworldtables1_2.html) (Accessed: November 23, 2005)

EIA, 2004c: *North Central Europe Country Analysis Brief* (Online) Available from: <http://www.eia.doe.gov/emeu/cabs/visegrad.html> (Accessed: October 6, 2005)

EIA, 2005a: *OPEC Brief* (Online) Available from: <http://www.eia.doe.gov/emeu/cabs/opec.html> (Accessed: November 23, 2005)

EIA, 2005b: *Russia Country Analysis Brief* (Online) Available from: <http://www.eia.doe.gov/emeu/cabs/russia.pdf> (Accessed: October 4, 2005)

EIA, 2005c: *European Union Regional Indicators* (Online) Available from: <http://www.eia.doe.gov/emeu/cabs/euro.pdf> (Accessed: October 4, 2005)

EIA, 2005d: *North Sea Country Analysis Brief* (Online) Available from: [http://www.eia.doe.gov/cabs/North\\_Sea/pdf.pdf](http://www.eia.doe.gov/cabs/North_Sea/pdf.pdf) (Accessed: October 4, 2005)

EIA, 2005e: *Nigeria Country Analysis Brief* (Online) Available from: <http://www.eia.doe.gov/emeu/cabs/nigeria.html> (Accessed: October 6, 2005)

EIA, 2005f: *Algeria Country Analysis Brief* (Online) Available from: <http://www.eia.doe.gov/emeu/cabs/algeria.html> (Accessed: October 6, 2005)

EIA, 2005g: *Libya Country Analysis Brief* (Online) Available from: <http://www.eia.doe.gov/emeu/cabs/libya.html> (Accessed: October 6, 2005)

- European Investment Bank (EIB), 2005: *Role and organisation of the EIB* (Online) Available from: <http://www.eib.eu.int/about/> (Accessed: November 29, 2005)
- European Integrated Pollution and Prevention Control Bureau (EIPPCB), 2003: *Reference Document on Best Available Techniques for Mineral Oil and Gas Refineries* (Online) Available from: <http://eippcb.jrc.es/pages/FActivities.htm> (Accessed: November 16, 2005)
- European Parliament and Council (EPC), 1999: *Council Directive 1999/32/EC relating to a reduction in the sulphur content of certain liquid fuels and amending Directive 93/12/ECC* (Online) Available from: <http://europa.eu.int/eur-lex/lex/LexUriServ/LexUriServ.do?uri=CELEX:31999L0032:EN:HTML> (Accessed: September 29, 2005)
- EPC, 2001: *Directive 2001/81/EC on national emission ceilings for certain atmospheric pollutants* (Online) Available from: [http://europa.eu.int/eur-lex/pri/en/oj/dat/2001/l\\_309/l\\_30920011127en00220030.pdf](http://europa.eu.int/eur-lex/pri/en/oj/dat/2001/l_309/l_30920011127en00220030.pdf) (Accessed: September 29, 2005)
- EPC, 2003a: *Directive 2003/30/EC on the promotion of the use of biofuels or other renewable fuels for transport* (Online) Available from: [http://europa.eu.int/comm/energy/res/legislation/doc/biofuels/en\\_final.pdf](http://europa.eu.int/comm/energy/res/legislation/doc/biofuels/en_final.pdf) (Accessed: November 16, 2005)
- EPC, 2003b: *Directive 2003/17/EC amending Directive 98/70/EC relating to the quality of petrol and diesel fuels* (Online) Available from: [http://europa.eu.int/eur-lex/pri/en/oj/dat/2003/l\\_076/l\\_07620030322en00100019.pdf](http://europa.eu.int/eur-lex/pri/en/oj/dat/2003/l_076/l_07620030322en00100019.pdf) (Accessed: October 3, 2005)
- Evaluation of Socio-Economic Development (EVALSED), 2005a: *Methods & Techniques Planning and Structuring Evaluation: Formative Evaluation Description of the technique* (Online) Available from: [http://www.evaled.info/src/sourcebook2/techniques1\\_5.htm](http://www.evaled.info/src/sourcebook2/techniques1_5.htm) (Accessed: November 30, 2005)
- EVALSED, 2005b: *The main stages of evaluation: Ex-ante evaluation* (Online) Available from: [http://www.evaled.info/SRC/guide/guide\\_anxA.htm](http://www.evaled.info/SRC/guide/guide_anxA.htm) (Accessed: November 30, 2005)
- Exxon Mobil Corporation (EMC), 2002: *Role of Russia in World Energy Outlook* (Online) Available from: [http://www.exxonmobil.com/Corporate/Newsroom/SpchsIntvws/Corp\\_NR\\_SpchIntrvw\\_RT\\_021002.asp](http://www.exxonmobil.com/Corporate/Newsroom/SpchsIntvws/Corp_NR_SpchIntrvw_RT_021002.asp) (Accessed: October 4, 2005)



## **F**

Foddy, W., 1993: *Constructing Questions for Interviews and Questionnaires: Theory and Practice in Social Research*, Melbourne: Cambridge University Press

Foster Wheeler Corporation (FWC), 1999: *Upgrading Options for Processing Heavy Crudes* (Online) Available from:

[http://www.fwc.com/publications/tech\\_papers/oil\\_gas/aiche.cfm](http://www.fwc.com/publications/tech_papers/oil_gas/aiche.cfm) (Accessed: October 10, 2005)

FWC, 2004: *Developing Strategies to Meet the Latest Clean Fuels Specifications* (Online) Available from: [http://www.fwc.com/publications/tech\\_papers/oil\\_gas/ARTC.pdf](http://www.fwc.com/publications/tech_papers/oil_gas/ARTC.pdf) (Accessed: November 21, 2005)

## **G**

Gacek, U., 2003: *Poland's Oil Sector – 9<sup>th</sup> Edition*, ISBN: 83-89530-00-7. Poland – Tarnów: Red Square Publishing

Gaspar, D. 1999: *Problems in the Logical Framework Approach and the challenges for Project Cycle Management*, The Courier - Jan/Feb 1999, 173, 75-77. Brussels: European Commission

Grupa Lotos (GL), 2000: *Annual Report 2000* (Online) Available from: <http://www.lotos.pl/p/u/raporty/eng/raport2000.pdf> (Accessed: November 29, 2005)

GL, 2002: *Annual Report 2002* (Online) Available from: <http://www.lotos.pl/p/u/raporty/eng/raport2002.pdf> (Accessed: November 29, 2005)

GL, 2003: *Annual Report 2003* (Online) Available from: <http://www.lotos.pl/p/u/raporty/eng/raport2003.pdf> (Accessed: November 29, 2005)

GL, 2004a: *Annual Report 2004* (Online) Available from: <http://www.lotos.pl/p/u/raporty/eng/raport2004.pdf> (Accessed: November 29, 2005)

GL, 2004b: *Planowanie rozwoju technicznego Grupy LOTOS*. GL's internal documents - presentation prepared by Department of Planning and Preparation of Investments (2004.10.22)

GL 2004/2005: *Projekt Kompleksowego Rozwoju Technicznego (Comprehensive Technological Upgrade Project)* – GL's internal report of the team appointed to develop comprehensive technological development strategy for GL

GL, 2005: Prospekt emisyjny akcji Grupa LOTOS (*Issue Prospectus for shares in GL*) (Online) Available from: [http://www.ir.lotos.pl/pliki/Grupa\\_LOTOS\\_prospekt.pdf](http://www.ir.lotos.pl/pliki/Grupa_LOTOS_prospekt.pdf) (Accessed: December 2, 2005)

Główny Urząd Statystyczny (GUS), 2005: *How to order statistical data?* (Online) Available from: [http://www.stat.gov.pl/english/sprzedaz\\_dane/index.htm](http://www.stat.gov.pl/english/sprzedaz_dane/index.htm) (Accessed: December 15, 2005)

## **H**

Hydro, 2005: *Crude oil Russia* (Online) Available from: [http://www.hydro.com/en/our\\_business/oil\\_energy/sales\\_distribution/products/crude\\_oil\\_russia.html](http://www.hydro.com/en/our_business/oil_energy/sales_distribution/products/crude_oil_russia.html) (Accessed: October 12, 2005)

## **I**

Interventions Ltd., 2003: *The Logical Framework Approach* (Online) Available from: <http://www.interventions.org/lfaintro.html> (Accessed: December 1, 2005)

Institute for the Analysis of Global Security (IAGS), 2004: *North Sea oil is declining* (Online) Available from: <http://www.iags.org/n0524043.htm> (Accessed: October 4, 2005)

ICF, 2005: *The Emerging Oil Refinery Capacity Crunch: A Global Clean Products Outlook* (Online) <http://www.icfconsulting.com/Markets/Energy/Marketing/refinery-capacity.pdf> (Accessed: October 6, 2005)

International Development Research Centre (IDRC), 2001: *The Temporal logic Model<sup>TM</sup>*, A Concept Paper (Online) Available from: <http://www.idrc.ca/uploads/user-S/10553603900tlmconceptpaper.pdf> (Accessed: December 1, 2005)

International Energy Agency (IEA), 2004a: *World Energy Outlook: Challenges for Europe 2004* (Online) Available from: [http://www.iea.org/textbase/speech/2004/nvh\\_scheveningen.pdf](http://www.iea.org/textbase/speech/2004/nvh_scheveningen.pdf) (Accessed: September 27, 2005)

IEA, 2004b: *Key world Energy Statistics: Emissions* (Online) Available from: <http://www.iea.org/dbtw-wpd/Textbase/nppdf/free/2004/keyworld2004.pdf> (Accessed: October 5, 2005)

IEA, 2005a: *IEA Monthly Oil Market Report, 9 September 2005* Available from: <http://omrpublic.iea.org/currentissues/full.pdf> (Accessed: October 3, 2005)

IEA, 2005b: *IEA Monthly Oil Market Report dated 9 September 2005* (Online) Available from: [http://omrpublic.iea.org/demand/reg\\_pi.pdf](http://omrpublic.iea.org/demand/reg_pi.pdf) (Accessed: October 5, 2005)

IEA, 2005c: *Oil Market Report Archives: Prices* (Online) Available from: <http://omrpublic.iea.org/archiveresults.asp?formsection=prices&formdate=%25&Submit=Submit> (Accessed: October 13, 2005)

IFP, 2002a: *Reducing CO<sub>2</sub> emissions from transport* (Online) Available from: [http://www.ifp.fr/IFP/en/ifp/ab04\\_04.htm](http://www.ifp.fr/IFP/en/ifp/ab04_04.htm) (Accessed: September 29, 2005)

IFP, 2002b *Preventing pollution related to transport* (Online) Available from: [http://www.ifp.fr/IFP/en/ifp/ab04\\_03.htm](http://www.ifp.fr/IFP/en/ifp/ab04_03.htm) (Accessed: October 3, 2005)

IFP, 2005: *Road Transport Fuels in Europe: the Explosion of Demand for Diesel Fuel, Panorama 2005* (Online) Available from: [http://www.ifp.fr/IFP/en/files/cinfo/IFP-Panorama05\\_10-CarburantsRoutiersVA.pdf](http://www.ifp.fr/IFP/en/files/cinfo/IFP-Panorama05_10-CarburantsRoutiersVA.pdf) (Accessed: October 5, 2005)

International Labour Organisation (ILO), 1999: *Employment and Industrial Relations Issues in Oil Refining* (Online) Available from: <http://www.ilo.org/public/english/dialogue/sector/techmeet/tmor98/tmorr.htm> (Accessed: October 10, 2005)

## **J**

Jackson, B., 1997: *Designing Projects and Projects Evaluations Using The Logical Framework Approach*, International Union for the Conservation of Nature and Natural Resources (Online) Available from:

<http://www.iucn.org/programme/files/LogframePaper3.pdf> (Accessed: December 2, 2005)

Jacobs Consultancy (JC), 2003: *The Gasification of Refinery Residual Oil and Subsequent Generation of Electricity* (Online) Available from: <http://www.jacobsconsultancy.com/pdfs/IDGTE%20PAPER.pdf> (Accessed: November 25, 2005)

Japan International Cooperation Agency (JICA), 2004: *JICA Guideline for Project Evaluation* (Online) Available from:

<http://www.jica.go.jp/english/evaluation/guideline.html> (Accessed: November 25, 2005)

## **K**

Kublik A., D. Malinowski, 2005: *Gigantyczne inwestycje przywiążą Grupę Lotos do rosyjskiej ropy*, Gazeta Wyborcza, May 22, 2005

## **L**

Lopez, M., 2000: *An Evaluation Theory Perspective of the Architecture Tradeoff Analysis Method: 2 evaluation Concepts*, Technical Report CMU/SEI-TR-012 (Online) Available

from: <http://www.sei.cmu.edu/pub/documents/00.reports/pdf/00tr012.pdf> (Accessed: November 30, 2005)

## M

Middle East Economic Survey (MEES), 2005: *Sour Crude Pricing: A Pressing Global Issue* (Online) Available from: <http://www.mees.com/postedarticles/oped/v48n14-5OD01.htm> (Accessed: October 13, 2005)

Ministerstwo Gospodarki i Pracy (MGIP), 2005: *Ministry of Economy and Labour: Energy policy of Poland UNTIL 2025* (Online) Available from: [http://www.mgip.gov.pl/NR/rdonlyres/20205452-144A-4325-8935-B4C95FB29DBD/0/energetyka\\_do\\_2025\\_ang.doc](http://www.mgip.gov.pl/NR/rdonlyres/20205452-144A-4325-8935-B4C95FB29DBD/0/energetyka_do_2025_ang.doc) (Accessed: December 2, 2005)

Ministerstwo Skarbu Państwa (MSP), 2003: *Ministry of the Treasury: Privatisation Lines for Treasury Assets in 2004* (Online) Available from: [www.msp.gov.pl/download.php?s=3&id=13](http://www.msp.gov.pl/download.php?s=3&id=13) (Accessed: December 2, 2005)

## N

Nexant Chem Systems (Nexant), 2004: *Financial-economic report on GL's Comprehensive Technological Upgrade Project*, GL's internal documents - Confidential report prepared for GL

Norwegian Agency for Development (NORAD), 1999: *Handbook for objectives oriented planning: The Logical Framework Approach* (Online) Available from: <http://www.baltichealth.org/getfile.php/11071.354/LFA%20handbook.pdf> (Accessed December 2, 2005)

## O

Organisation for Economic Co-operation and Development (OECD), 2002: *Glossary of Key Terms in Evaluation and Results Based Management* (Online) Available from: <http://www.oecd.org/dataoecd/29/21/2754804.pdf> (Accessed: November 29, 2005)

Organisation of Petroleum Exporting Countries (OPEC), 2005: *Global oil outlook: Challenges & opportunities for OPEC* (Online) Available from: <http://www.opec.org/opecna/Speeches/2005/EUEnerFor.htm> (Accessed: October 4, 2005)

## R

Robson, C., 2002: *Real World Research: A Resource for Social Scientists and Practitioner-Researchers* - Second Edition, Blackwell Publishers Inc., USA

## S

Swedish International Development Agency (SIDA), 2004: *A summary of the theory behind the LFA method* (Online) Available from:

[http://www.sida.se/shared/jsp/download.jsp?f=SIDA1489en\\_web.pdf&a=2379](http://www.sida.se/shared/jsp/download.jsp?f=SIDA1489en_web.pdf&a=2379) (Accessed: November 30, 2005)

## U

United Nations Economic Commission for Europe (UNECE), 2005: *Convention on Long-range Transboundary Air Pollution* (Online) Available from: [http://www.unece.org/env/lrtap/lrtap\\_h1.htm](http://www.unece.org/env/lrtap/lrtap_h1.htm) (Accessed: September 29, 2005)

United Nations Framework Convention on Climate Change (UNFCCC), 2005: *Kyoto Protocol - What it means* (Online) Available from: <http://unfccc.int/2860.php> (Accessed: October 3, 2005)

United States Embassy (USE), 2003: *US Embassy Warsaw Press Releases and Announcements* (Online) Available from: <http://poland.usembassy.gov/poland/refinery.html> (Accessed: November 29, 2005)

## W

Wikipedia, 2005: *Brent Crude* (Online) Available from: [http://en.wikipedia.org/wiki/Brent\\_crude](http://en.wikipedia.org/wiki/Brent_crude) (Accessed: September 22, 2005)

World Bank, 2004: *Crude Oil Prices* (Online) Available from: <http://rru.worldbank.org/Documents/PapersLinks/275-bacon-tordo.pdf> (Accessed: September 22, 2005)

World Commission on Environment and Development (WCED), 1987: *Our Common Future*, London: Clays Ltd

## Y

Yin, Robert K., 1984: *Case Study Research: Design and Methods*, SAGE Publications, Inc.

## Z

Zgoda, G., S. Pokojski, K. Sep, 2005: *Logical question list of the RUP – Interview*, Gdańsk, 2005. Available from: Appendix C of this report

## **Appendix A: Subsidiaries of Grupa LOTOS**

### **Rafineria Czechowice**

The company is currently engaged in manufacturing and processing products obtained as a result of refining crude oil as well as their sale on the retail and wholesale levels. The main area of activity is the production and sale of light and heavy heating oil, fuel components, as well as the storage of motor fuels. Rafineria Czechowice is to be transformed into a fuels storage-distribution centre. In connection with the planned liquidation of excise allowances, the company intends to resign from petroleum distillation after 2006, because this activity is becoming unprofitable. Within Grupa LOTOS, Rafineria Czechowice will become a storage-distribution Centre.

### **Rafineria Jasło**

Rafineria Jasło is engaged in manufacturing and processing products from refined petroleum, storing and selling fuels and recycling used oils and plastics. The most important products offered by Rafineria Jasło include diesel fuel, petrol, as well as medium and heavy heating oil. Within Grupa LOTOS, Rafineria Jasło is to become a recycling centre engaged in processing plastic waste, spent oils, precipitates as well as residues. Due to the liquidation of excise allowances, oil processing in this refinery will be limited to the amount technologically necessary for processing waste.

### **Petrobaltic**

Within Grupa LOTOS, Petrobaltic comprises the exploration and production segment, the strategic goal of which is exploring and exploiting new hydrocarbon deposits in Poland and abroad in order to ensure deliveries of petroleum and products obtained from natural gas. Currently, Petrobaltic's entire output is sold to Grupa LOTOS.

### **LOTOS Paliwa**

LOTOS Paliwa is located in Gdańsk, and is a wholly owned subsidiary of Grupa LOTOS. The company conducts nation-wide sales of fuels and light heating oil on the wholesale and retail levels, excluding sales to foreign concerns and tenders with a nation-wide character. As a result of reorganising Grupa LOTOS' market segment on 3 January 2005, the company became the exclusive distributor of the fuels and light heating oil of Grupa LOTOS.

### **LOTOS Partner**

The activity of LOTOS Partner is concentrated on the sale of fuels and servicing the retail networks of foreign concerns. The company is also engaged in the distribution of Jet A-1 fuel on the domestic market. LOTOS Partner activities are concentrated on primary logistics, importing fuels by land, supplying the petrol station networks of foreign concerns as well as servicing nation-wide tenders

### **LOTOS Mazowsze**

LOTOS Mazowsze is engaged in the sale of liquefied petroleum gas (LPG), heavy heating oil as well as special and niche products manufactured by Grupa LOTOS and the southern refineries (sulphur, softening agents, fuels with recycled components).

### **LOTOS Oil**

LOTOS Oil is engaged in the production and distribution of finished motor and industrial oils and lubricants (domestic and foreign markets) as well as the distribution of base oils (domestic market), cosmetics and automotive chemicals. In 2004, LOTOS Oil has an approximate 30% share in the market of lubricants, which in recent years has been characterised by a growth trend.

### **LOTOS Asphalt**

LOTOS Asphalt is engaged in the production and sale of asphalts. It is currently the exclusive client of components for the production of asphalts from Grupa LOTOS. Production is dominated by road asphalts (common and modified), with marginal quantities of industrial asphalts, asphalt emulsions and asphalt cements also being produced. Sales are largely conducted on the domestic market. LOTOS Asphalt is the leader in the field of modified asphalts. The company's main competitors are Orlen Asphalt and BP Bitumen. In 2004 LOTOS Asphalt had an approximate 36% share in asphalt sales on the Polish market.

### **LOTOS Kolej**

LOTOS Kolej was established on the basis of Grupa LOTOS assets, and is engaged in providing comprehensive rail services to the Group. These include rail transport, freight settlement, tanker management as well as representing the interests of the Group in contacts with PKP (Polish State Railways), operators, tanker owners and forwarding companies. In February 2004, LOTOS Kolej took over rail services for the Southern Refineries (including the transfer of employees and leasing of assets). Other significant duties carried out by LOTOS Kolej include conducting licensed transportation throughout the entire country and maintenance of infrastructure, rolling stock and other fixed assets of operated rail sidings. Moreover, LOTOS Kolej leases out tankers for transportation of liquid gases and offers rail and road tanker cleaning services at the Jasło Refinery.

### **LOTOS Ekoenergia**

LOTOS Ekoenergia is a wholly owned subsidiary of Grupa LOTOS, located in Gdansk. The company was specifically established in 2002 to execute GL's residue-upgrading project (RUP) encompassing the construction of three units, i.e. the SDA/ROSE Solvent DeAsphalting Unit, MHC mild hydrocracking unit and IGCC heavy residue gasification unit. The major portion of RUP will be financed, built and operated by LOTOS Ekoenergia. Grupa LOTOS will conduct investments aimed at adapting the increased processing capacity thereby making co-operation with the complex as well as carry out the required adaptations to infrastructure and their expansion and modernisation. The use of

project finance for the RUP will enable the necessary bank finance to be raised, without burdening Grupa LOTOS with debt repayments, partners/investors being attracted, possessing the know-how connected with applying the latest technologies (licences, designs, guarantees of correct execution and operation).

### **LOTOS Serwis**

LOTOS Serwis (created on the basis of the maintenance services of Grupa LOTOS) is engaged in providing maintenance and repair services for equipment and units as well as implementing investments on behalf of the Group and other companies.

### **LOTOS Lab**

LOTOS Lab (created on the basis of Grupa LOTOS assets) is engaged in performing laboratory tests. The objective of LOTOS Lab is to provide analytical services within the scope of crude oil, oil products, water, effluent and certain chemicals, as well as conduct measurements and document work environment conditions. LOTOS Lab has obtained the rigorous PN-EN ISO/IEC 17025:2001 quality standard certificate, making it an accredited laboratory, which significantly facilitates its operation on the market. The scope of accreditation encompasses 52 research methods concerning testing of raw materials, intermediate products and oil products as well as water, effluent and the work environment. LOTOS Lab has contracts signed with all interested companies within the Group and is intensively increasing the amount of tests conducted for external customers, which currently account for only a minor share of its revenue structure.

### **LOTOS Straż**

LOTOS Straż (created on the basis of Grupa LOTOS assets) provides services within the area of fire prevention, encompassing operational and rescue actions, fire safety, issuing opinions on documentation, granting approvals and providing training services. LOTOS Straż is obliged to provide services within the scope of fire prevention to the Grupa LOTOS. It can also provide services to other companies, exclusively on the site of the Gdańsk refinery. This restriction results from the need to maintain a fixed, high level of fire safety at the refinery.

### **LOTOS Ochrona**

LOTOS Ochrona (created on the basis of Grupa LOTOS assets) is engaged in providing security services. LOTOS Ochrona provides services to the Group as well as other companies.





## **Appendix B: Brief description of GL's PROSTA**

The following appendix presents a brief description of Grupa LOTOS' Petrol Station Network Development Programme within the framework of which GL plans to obtain a 12% share on the retail fuel market in 2010. This is to occur as a result of increasing the number of petrol stations up to 500 from the current 352 as well as increasing the average annual volume of fuel sold per station.

The GL's network is comprised of company-owned, patron and partner stations. The increase in the number of petrol stations will occur in conjunction with the change in the ownership structure of the network. Patron stations dominate in the current structure of stations selling fuels under the GL brand. These stations are owned by companies or individuals, which have signed co-operation agreements with GL. However, agreements signed several years ago do not adequately protect GL interests. As a result, the quality of services offered at these stations has not always been satisfactory and has resulted in the possibility of corrupt practices on the part of some owners. Agreements currently signed precisely regulate the principles of co-operation between the parties. GL is conducting a policy of consistently reducing the number of patron stations through terminating agreements (in the case of stations with weak sales) or through signing partner agreements (in the case of well-located stations with the appropriate standard). The goal of GL is to conduct retail sales primarily through its own stations, as well as partner stations, as complete control over the delivery of fuels and other goods is possible in these stations. Therefore, GL will purchase some of the patron stations, some patron stations will become partner stations, and co-operation with some other patron stations will be terminated.

Considering the reduction in the number of patron stations, GL intends to acquire 150-300 new stations within the course of about 2 years. Environmental norms concerning petrol stations will change in 2006 and the majority of stations operating in Poland will be forced to bear investment expenditures of about 100 thousand USD in order to remain on the market. The costs of liquidating a station (land reclamation, transporting scrap, etc.) are estimated at approximately 107 thousand USD. Therefore, the implementation of new environmental regulations could be a very good opportunity for GL to acquire financially weak entities.

The PROSTA also involves a plan to standardise the appearance of the petrol stations. To date, GL stations have operated under two brands (Rafineria Gdanska and LOTOS). The large share of patron stations, the owners of which they determined the offer of available products and services, resulted in the offers of individual stations in the same network considerably differing from one another. Work currently continues on developing a uniform appearance for GL stations as well as standardising their services. This is in keeping with the significant increase in the quality of services.

A subsequent step will be conducting a promotional marketing campaign at GL stations. Currently, the small number of stations as well as the significant differences in offered products and services result in marketing activities having a limited influence on the perception of these stations on the market. Therefore, GL decided to launch promotional activities following the expansion and standardisation of the network.

## Appendix C: Logical question list of the RUP – Interview

Answers to the following questions elucidate the RUP's outline or description and have been an inspiration for the logical analysis of the RUP and its evaluation. These questions have been elaborated based on the Logical Framework Approach method. The interview has been completed by the following representatives from GL:

Grzegorz Zgoda – Director of investment affairs (28<sup>th</sup> of April, 2005)

Stanisław Pokojski – Manger of financing office (25<sup>th</sup> of July, 2005)

Karol Sep – Department of Planning and Preparation of Investments (25<sup>th</sup> of July, 2005)

### Problem analysis

1. Why is the residue-upgrading project needed? What are the main problems that shall be solved with the aid of the project?

*The project is needed in order to solve the problem of heavy petroleum processing residues.*

*In order to dispose of the residual oil the refinery have had to blend them with lighter gas oils in order to sell them as commercial fuel for ships and utilities. However, even these are facing tighter sulphur content controls.*

*In addition using the surplus vacuum residue as refinery fuel component after satisfying the base oils and bitumen manufacturing requirements will not be acceptable solution. Currently HFO is mixed with more expensive gas oil to meet sulphur emission level of 3500 mg/ Nm<sup>3</sup>. However to meet sulphur limit of 1700mg/Nm<sup>3</sup> which is legally binding for Poland from January 2007 we will have to add even larger amounts of good quality cutter stock to meet sulphur limit. As a result, the cost of the marginal mixed fuel will become higher than the cost of the refinery's highest cost fuel.*

2. What are the causes of the problems?

*Processing sour crude results in larger amounts of heavy residues with higher sulphur content. GL has been processing oil mainly from Russia (Ural crude) and we do not foresee changes in the origin of the raw material because processing Urals proves to be the most profitable due to the logistics and lower purchasing cost compared to oil from other sources. Currently the company has insufficient technology to convert heavy residues into lighter, higher value products.*

*In January 2005, one of the suppliers suspended its deliveries of the Russian oil to Polish refineries). After that GL launched a special programme providing for purchase oil from other sources, using the currently operating infrastructure.*

### 3. What consequences do the problems have?

*High SO<sub>2</sub> emissions from the refinery site and low share of “white” products for which demand is increasing on both the domestic and the EU market.*

*The strategy adopted by Grupa LOTOS assumes increasing market share and achieving a position of leader or second placed company in its main product segments, including above all fuel. At the moment, the share of transport fuels is too small (because of significant production of HSFO) to influence the market.*

*The principal competitor of the GL on the domestic market is the PKN Orlen Group. In addition to the competition from Polish companies, foreign competitors will also affect the GL's growth opportunities and prospects. Refining groups with a total annual throughput capacity of approx. 125Mt of crude oil operate in Poland's imminent vicinity (Eastern Germany, the Czech Republic, Slovakia, Hungary, Western Ukraine, Lithuania, Belarus, Scandinavia). The significance of imports as a source of competition is also expected to grow. This refers particularly to imports from the Czech Republic, Slovakia, Belarus, Lithuania, Ukraine and Russia. Following the upgrade of the Belarus refineries, the range of imported products will be extended to include gasolines, and the import will focus on Central and Eastern Poland.*

*Currently the company owns 21% of wholesale market and 6% of retail market. We intend to increase the share in the wholesale and retail market to 30% and 12% in 2010, respectively.*

#### **Objectives' Analysis**

### 4. What are the long-term, social and / or economic benefits to which the project will contribute? Why is the planned project important for beneficiaries and society (country, region)?

*The project will improve the financial as well as environmental performance of the refinery and contribute to increased share in the wholesale and the retail fuel market in Poland.*

*After its completion in 2009 the company will be able to process heavy refinery residues to lighter fractions. On account of EU standards, the input components to installation will be cheaper than crude oil, which will significantly increase realised margins. We assume that with oil prices of USD 20-25 bbl of Ural the overall margin including variable cost after completion of the investment will increase from 150 up to 355USD million per year.*

*Project is going to permit the reduction of emissions, mainly of sulphur dioxide, into the air, at both local scale by substituting a synthetic gas fired energy unit for the existing electric heating facility fired using sulphur-rich fuel oil (SO<sub>2</sub> emissions will be reduced*

from 5497 to 311 tons p.a.), and also on global scale due to eliminated HSFO production secondary SO<sub>2</sub> emissions will be reduced by approximately 45,000 tons p.a.

5. What is the project's purpose in concrete, realistic and – if possible – measurable terms?

*Currently we produce 0,8 million tons p.a. of HFO. After completion of the RUP this production will cease while 10 ppm S transport fuels production will increase. Gasoline from 1,15 to 1,69 Mt/p.a, Diesel from 1,43 to 2,45 Mt/p.a, JET A-1 from 0,54 to 0,75 Mt/p.a*

*IGCC complex will provide environmentally generated power and steam for refinery use (balance to 44 MWe and 72MWh) and cost effective hydrogen production (216t/d) for meeting product specifications*

6. What concrete results should the activities lead to? What goods or services is the project expected to supply to the target group?

*Very advanced technology comprising of:*

- *A deasphalting unit (ROSE™ process) to separate asphaltenes from the vacuum/atmospheric residue feed*
- *A world-scale hydrocracker to process deasphalted oils (DAO) – primarily to low-sulphur diesel and hydrowax (desulphurised oil)*
- *A Shell gasification unit to produce hydrogen for the hydrocracker and syngas as a source of clean fuel for the power plant as an integrated gasification combined cycle (IGCC)*
- *A cogeneration power plant with two gas turbines and two steam-turbine generators that will utilise the syngas not required for the production of hydrogen and the steam generated by the waste heat boilers of the gasification process.*

### **Resources/Activities**

7. What resources/ inputs (human, financial and material) need to be allocated to guarantee that the project can be implemented? /What are the main activities to produce the project output?

*Technology (IGCC, ROSE, MHC units), expert knowledge for implementation of the RUP (Shell Global Solution and Kellog Brown & Root) funds for:*

*Main installations:*

*SDA - 55 USD million*

*MHC - 165 USD million*

*IGCC - 365 USD million*

*Associated upgrades - 89 USD million*

*Offsite - 69 USD million*

*License fees - 15 USD million*

*Operating/maintenance -55 USD million per annum*

*There is a detailed description of the activities in our 'Comprehensive Technological Upgrade Project' report.*

8. Have specific dates been determined for the planned start and completion of each activity? What dates?

- *2006 - tenders for technical designs and construction work, execution of the base projects*
- *End of 2006 - financial closure*
- *2007-2009 - execution of the project construction contracts*
- *May 2009 - start-up and commencement of operations*

### **Risk Factors**

9. Assess the risks related to the execution of the RUP. What can be done about them?

*Major risks related to the execution of the RUP include high costs of investments provided for under the Project, which together with the investment reserve and loan interest expense during the construction period are estimated at approx. USD 800 million. For comparison, the value of GL previous major investments was approximately USD 85 million for catalytic reforming, launched in 1995, and approximately USD 430 million for the hydrocracking unit in 2000.*

*A large portion of the capital expenditure (approx. 65%) will be financed with debt instruments. With a view to reducing the effect of this risk on the GL's operations, a part of the project will be executed by LOTOS Ekoenergia (LESA), a special purpose vehicle (SPV) wholly-owned by GL. Funds from the shares has been used to raise equity of LESA. GL will be able to finance 10% of the value of investment while the remaining will be supplied by LESA (company funds and bank loans).*

*The new units which are part of the RUP (IGCC, MHC, ROSE) will be financed, built and used by LESA. Although at LESA, the units will be used in a manner fully synchronised with other units belonging to the GL. We expect that the parties co-financing the RUP may become shareholders in LESA, however, we intend to keep an over 50% share in the company's share capital.*

*In line with the currently planned financing structure of the RUP, LESA will finance the investment projects on a non-recourse basis. The liability towards the financing institutions will be limited to the balance sheet of the LESA, and the repayment of the*

*liabilities incurred by LESA to finance the RUP will be secured with long-term offtake contracts concluded by the SPV.*

*The letter of intent signed between Shell International Trading and Shipping Company – (STASCO) - Shell subsidiary and LESA concerns the long-term receipt (12 years) of significant amounts of hydrowax and smaller amounts of diesel oil from the RUP. Terms of purchase will be based on the price formula described in the contract linked to market quotations. Full entry into force of this contract is conditional on financial closure of the RUP and initiation of operating activity as part of this project within 48 months of financial closure.*

*The contract will meet the requirements of the financial institutions, and will ensure that the SPV has the necessary revenue in time to service the debt incurred during the execution of the RUP.*

*Given the scope and duration (2006–2009) of the project, there may occur delays in its execution. In order to reduce this risk, turnkey contracts providing for specific delivery dates and prices, as well as the right to claim compensation, are being negotiated. Moreover, each stage of the project's execution will be subject to a strict budget control, and work on the project will be commissioned to contractors experienced in the execution of such projects.*

*Execution of the RUP also involves the need to secure supplementary feedstock from external sources to enable production in new refinery units, as GL is currently unable to produce sufficient amounts of this type of feedstock. With a view to reducing the risk, an agreement for additional supplies of refining residue from outside of the Gdańsk refinery need to be concluded for a period necessary to develop the capacity necessary to produce this type of feedstock by the company itself. Until then, the units at the Gdańsk refinery used for feedstock pre-treatment may be expanded to enable production of the necessary amount of feedstock. Upon the project completion, it will be possible to discontinue imports of heavy feedstock and replace it with crude oil, which will enable full provision of the Company's own feedstock to the RUP.*

*Furthermore, the risk related to the supplies of the supplementary feedstock is reduced by the access to the necessary infrastructure (pipeline connections to Port Północny of Gdańsk and PERN Przyjaźń SA).*

*Technological risks are related to possible breakdowns of the main RUP refinery units, i.e. the ROSE SDA deasphalting unit, the IGCC unit, and the mild hydrocracking unit; there is also a risk that these units may fail to meet the required operating parameters, or that the technology employed would have to be modified in response to market changes. With a view to minimising the technological risks, we plan to build the new refinery units based on reliable technologies of international concerns, such as Shell Global Solutions and*



*Kellogg Brown & Root, with whom the company plans to enter into maintenance agreements. Moreover, technology assessment of the main units is provided by independent consultants, while contracts for delivery and installation of the units will provide for penalty payable by contractors if the units fail to meet the required operating parameters.*

10. Is there any decisive factor, which is a precondition for the success of the project?  
Which factor?

*Financing must be assured in order to start the project.*

*Along with increasing the efficiency of installations and expanding production capacity, increasing market share will largely depend on the distribution network.*

*Within the framework of PROSTA GL plans to obtain a 12% share on the retail fuel market in 2010. This is to occur as a result of increasing the number of petrol stations up to 500 from the current 352 as well as increasing the average annual volume of fuel sold per station.*

#### **Side-effects**

11. What negative and/or positive (intended or unintended) side-effects can the project bring about?

*Implementation of the RUP will secure or even expand employment and business opportunities in the region e.g. civil engineering works.*

*IGCC installation will significantly reduce SO<sub>2</sub> emissions but at the same time it will be responsible for threefold increase in CO<sub>2</sub> emission up to 2800 t CO<sub>2</sub>/year. However IGCC is the most efficient technology in energy production (less CO<sub>2</sub> is emitted per unit of electric power produced) and EU recommends IGCC installations.*

#### **Strategy analysis**

12. Have alternative strategies been considered to reach the planned project objective/purpose? If yes – what strategies?

*The alternative strategies have been presented in our internal presentations.*

#### **Stakeholder analysis**

13. What are the main stakeholders (beneficiaries/target group, implementers, decision makers, financiers), which play a significant role in the success of the RUP?

*Grupa Lotos is entity who will be directly and positively affected by the project. However the project will be implemented, supervised and managed along through a company specially created for this purpose, LESA.*

*GL has concluded an agreement according to which a part of the licence fees under licence agreements for use by the GL of the ROSE (residue oil supercritical extraction), MHC (mild hydrocracking) and IGCC (gasification) technologies was covered by the offset programme based on an offset agreement executed by the State Treasury and Lockhead Martin Corporation. The information on the provisions of the agreement between the GL and Lockhead Martin Corporation has been covered by non-disclosure application.*

*The company has also signed agreements with Shell Global Solutions and MW Kellogg Limited. The agreement comprise in particular the provision of advisory services during the design, construction, start-up and operation of the RUP, and agreement concerning the basic service package (license information, technical or otherwise held by the licensor) including access by the GL and LESA to the most efficient refining processes.*

*Stakeholders that will constitute a core in financing the RUP and are crucial to formulate the strategy towards commercial banks include:*

- Bank Ochrony Środowiska (BOŚ) has signed an agreement with LESA aimed at arranging finance for the part of RUP directly connected with environmental protection (approx. USD 20 million)*
- European Bank for Reconstruction and Development (EBRD) has declared a capital engagement in the RUP for an amount constituting 20% of total capital expenditure (up to USD 40 million) and credit up to USD 170 million.*
- European Investment Bank EBI have signed a letter of intent with LESA, expressing its interest in financing up to 50% of the value of the RUP, with a long-term loan (of up to 16 years).*

*Their engagement in pro-environmental investments requires longer procedures...*

*Banks granting loans in the later stages of the project implementation include commercial banks such as Citibank Handlowy S.A., BRE Bank S.A., Nord LB Polska S.A., West LB Polska S.A., PeKaO S.A., Credit Lyonnais Polsak S.A., RfaiFFEisen Bank Polska S.A., Societe Generale etc.*